

2.2.2 Demolding through Sliders

Undercuts are depressions or recesses on injection molded parts that complicate the demolding or even make it impossible in extreme cases. Auxiliary parting planes can be generated with sliders to release partial molded part areas that have an undercut in the demolding direction.

Slider Mold with Cold Runner

Sliders are incorporated either into the nozzle or ejector side and move transversely to the opening direction of the mold. When the mold is opened, the slider runs to the side of the mold axis at an angle of 90° . A maximum deviation of 7° in both directions should not be exceeded or the slider tends to lock.

The movement of the slider is carried out mechanically by a sloping or control bolt, also called the positive control.

The movement of the slider can take place before, during, or after the opening of the mold, either mechanically or by means of springs, air, or hydraulic cylinders. When determining the dimension of sliders, the buoyancy force that arises in the mold has to be considered (see Section 1.3).

Typical applications include power strips, bobbins, clamps, dowels, and parts with external threads.

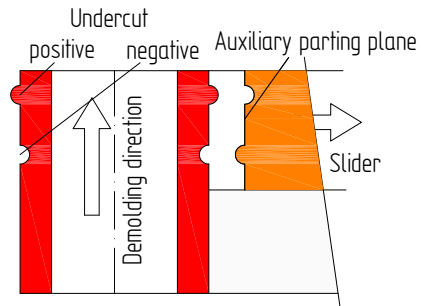

Figure 2.5 Principle of an undercut with slider



Figure 2.6 Injection molded part demolded with slider
(Source: Ferromatik Milacron)



In the slider molds, a slider runs out transversely to the mold axis when opening the mold. Thus, the molded part is released and the stripping is enabled.

2.2.3 Demolding with Jaws (Split Molds)

In split molds, two or more jaws completely enclose the molded part, in contrast to slider molds where only parts are released.

In slider molds, the mold cavity usually consists of one part. However in split molds, the jaws form the mold cavity. The jaws can be inserted diagonally on the nozzle side and they then move on the diagonal to the outside when the mold is opened by means of a pull tab. Thus, the injection molded part is released for demolding.

Alternatively, the jaws can also be guided on the ejector side, as with sliders. They are then moved, during or after the opening movement, mostly with hydraulic cylinders or mechanically using springs or air.

Jaws in all sizes should be necessarily integrated into the cooling circuits of the molds.

Split molds can be combined with all known manifold systems and gate variations. The sprue and the molded part fall out of the same parting plane and need to be sorted later.

A very typical application for split molds is the manufacture of bottle crates and car batteries.

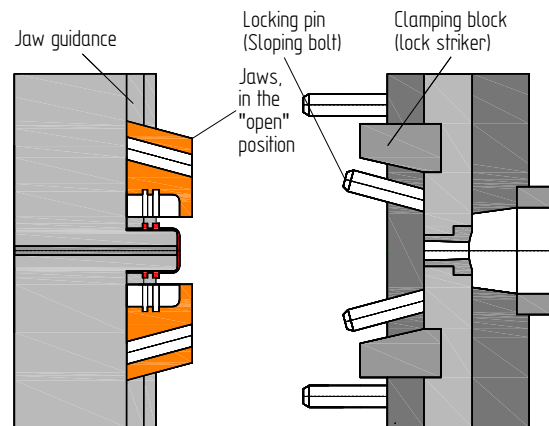

Figure 2.7 Principle of a split mold

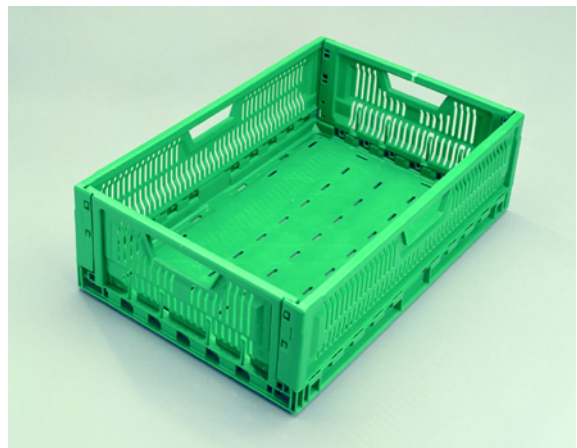

Figure 2.8 Injection molded part demolded with jaws
(Source: Ferromatik Milacron)



When starting up the machine, the jaws of the mold can be opened via a slope and the molded part is released for demolding.

2.2.4 Collapsible Cores

Collapsible cores are used when, besides threads, other undercuts must be released. These parts include tamper evidence bands, tear tabs on bottle caps or the like.

When using collapsible cores, one must ensure that the thread depth and the thread diameter are correlated. The thread depth is about 0.8–1.0 mm at a thread diameter of 28 mm. Therefore, no thread with a diameter of 28 mm and a thread depth of 3 mm can be produced with the collapsible core. However, this would always be possible using a rotary core.

This interdependence of thread depth and thread diameter results from the fact that the segments, which are arranged around a central core, can only fall so far inward until they lock themselves when the central core is pulled.

Applications can be found wherever the thread or a thread-like undercut on the molded part plays a minor role, such as covers used for resealable containers.

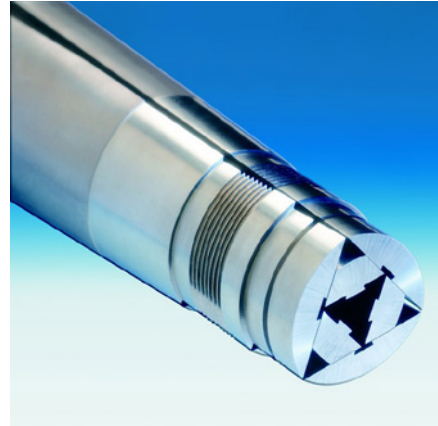

Figure 2.9 Collapsible core (Source: HASCO)



In general, threads or thread-like undercuts on injection molded parts with a diameter of between 15 mm and 500 mm can be produced with collapsible cores. When using collapsible cores, the plastic material being used is irrelevant.

2.3 Molded Parts with Internal and External Threads

- Considering the demolding direction, internal and external threads represent undercuts. These parts are demolded by rotating the threaded cores (for internal threads) or by turning the dies or cavities (for external threads).

2.3.1 Internal Thread

- Internal threads are located on a core with a thread profile, which is encapsulated during the injection. The molded part is smooth on the outer surface.

If parts with internal threads cannot be demolded elastically, demolding must be done by unscrewing or with collapsible cores.

2.3.2 External Thread

- External threads are usually created with jaws. The parting plane may not be visible, and the entire cavity is rotated.

For rotating the threaded cores or the cavities, a gear is installed in either the nozzle or ejector side. The gear is driven either by a servomotor, a hydraulic motor, a rack, or by a helical spindle that is pulled by a lead screw.

For both external and internal threads, the molded parts are held through the fluting on the periphery of the part or through specially attached twisting jaws. In the latter, the twisting jaws are often visible on the inside of the part. If this is not desired for the finished part, unscrewing must be done when the mold is closed.

2.3.3 Unscrewing Device

- To be able to unscrew the threaded core, the molded part must be secured against rotation. Several variants are available, depending on the shape of the molded part.



Figure 2.10 Injection molded parts with internal threads (Source: Ferromatik Milacron)

3.1.2.2 Hot Runner

3.1.2.2.1 Advantages of a Hot Runner

The hot runner is theoretically an extension of the injection unit. The hot runner should keep the liquid molten up into the mold cavity. It meets this requirement by guiding and heating the molten plastic until it reaches the mold cavity, with virtually no temperature and pressure losses.

The biggest advantage of the hot runner technology lies in waste-free injection and in good injection point quality. Disturbances in the production process by stuck sprue spiders in the open mold do not exist.

Another advantage is the positioning of the injection point. It can be selected easily so that a balanced filling of the molded part is guaranteed. Symmetrical filling means that injecting is done in the middle of the base. This takes place, for example, in all cylindrical shapes such as cups, buckets, or similar parts.

In irregular injection depths, all part surfaces are graphically projected onto one plane. A circle, which covers all subareas, is then drawn. If an injection in the center of this circle is possible, a symmetric filling of the molded part is ensured.

By eliminating disruptive distribution channels in the parting plane, design possibilities that are completely new for mold making can be obtained. The molds become more compact and the number of cavities in the molds is significantly increased. Molds with up to 128 mold cavities or more are not unusual.

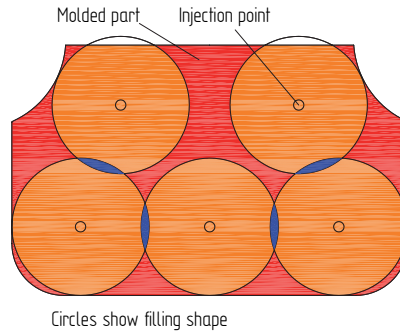

Figure 3.5 Principle of symmetrical filling



The hot runner technology guides the melt to the cavity with nearly no loss of temperature and pressure. Injecting without a gate eliminates the use of a sprue spider, which causes a substantial material and cycle time reduction.

3.1.2.2.2 Hot Runner, Internally Heated

Molds with internally heated hot runners belong to the beginnings of the hot runner technology and are now hardly ever built. A disadvantage of internally heated systems is the complexity involved when changing color or material.

The hot runner technology originated from the idea of developing an internally heated distribution and gating system from an insulating runner, which prevents solidifying of the runners when starting the mold. Therefore, a heating system was installed and placed in the center of the distribution channels.

The knowledge that no hot material can escape in places where cold, solidified material is located was an important condition for the tightness of the system. A big disadvantage occurred for color or material changes. Streaks formed on the molded part because material particles dissolved in the surface layers of the insulating layer. To rule this out, the entire system had to be disassembled for every color and material change and the material located in the distribution system had to be removed, which is a very complex procedure.

The heating system is located in the center of the mass flow. The heating elements are heating cartridges that regulate the temperature by means of sensors. The cartridges are almost self-insulating. The heat transfer into the cold mold is very low; this guarantees a low thermal expansion, and thus a high probability that the mold is sealed.

The internally heated system was preferably used for the processing of semicrystalline thermoplastics such as polyethylene (PE), polypropylene (PP), or polyamide (PA).

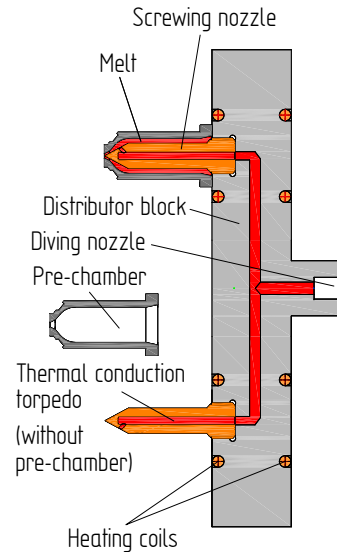

Figure 3.6 Principle of a hot runner system



The change of color and material is a major problem for internally heated hot runners. To still be able to inject perfect parts after a change, the distribution system is disassembled and material residue is removed. Therefore, the internally heated hot runner is hardly used today.

3.1.2.2.4 Multiple Connections

There are three different types of multiple connections: 1) one nozzle for multiple injection molded parts, 2) multiple nozzles for one molded part, and 3) multiple nozzles for multiple molded parts.

One Nozzle for Multiple Parts

This type of nozzle, also called a hot edge nozzle, is designed such that multiple parts can be injection molded with one nozzle (see Section 3.2.2.3).

Multiple Nozzles for One Injection Molded Part

This variant, also called cascade injection molding, is the classic version of multiple connections. Large and extremely long parts, such as automobile bumpers, are molded with multiple nozzles. Even parts with different levels, such as garden chairs, are molded with different lengths of hot runner nozzles. This process is preferably used when no clamping force reserve is present on the part of the injection molding machine (see Section 6.9 Cascade Injection).

Multiple Nozzles for Multiple Injection Molded Parts

When using multiple nozzles for multiple molded parts, it is important that the flow paths from the hot runner to the distributor are approximately the same length in all nozzles to prevent a nonuniform filling.

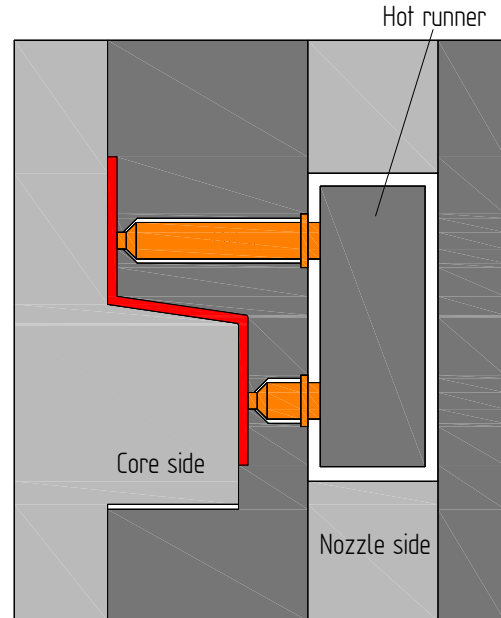

Figure 3.10 Principle of multiple connections



Multiple connections are especially used for very large molded parts. They allow molding, which is adapted to the injection molded part, with nozzles of varying lengths. Even with mass-produced parts, several molded parts can be connected with one nozzle for cost reasons.

6.2.5 Rotary disk

Multi-component molds with rotary disks are used in all areas of the plastics industry. Depending on the application, rotary disks can be driven hydraulically or with a servomotor.

The rotary disk is an economical solution for transporting the mold from one injection station to the next. The rotation of the mold is shifted to the rotary disk, whereby the injection mold becomes simpler.

Depending on the number of components, the rotary disk can be positioned in $4 \times 90^\circ$, $3 \times 120^\circ$, or $2 \times 180^\circ$ increments. In the simplest case, the rotary disk is pivoted by 180° to the left or right. The continuous rotation of the movable mold half is particularly useful for multi-station molds. The supply for cooling and hydraulics is accordingly complicated because the continuous rotation does not allow cable or hose connections.

A disadvantage of the rotary disk is the higher space requirement in the injection molding machine compared to other multi-component mold systems. Injection molding machines with rotary disks generally require a rail extension at a minimum of 200 mm. The distance between the rails is also increased by 50 – 100 mm.

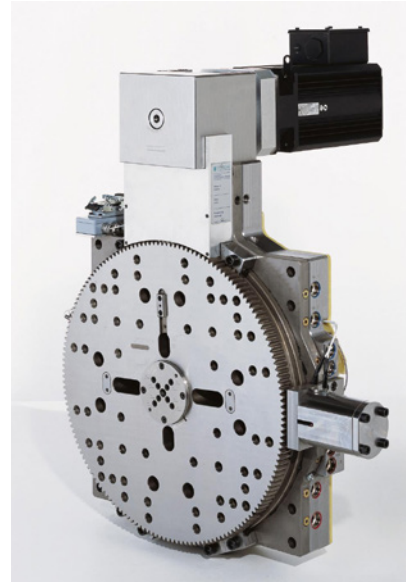

Figure 6.11 Rotary disk with servo drive
(Source: FOBOHA)



Compared to the transfer technique, rotary molds have the advantage of better positioning of the preform in the finishing station. Even more complex design variations of the cavities are possible.

6.2.7 Cube Technology

The advantage of the cube technology over other mold technologies is that the number of cavities for the same machine size can be doubled. Or in other words: for the same production lot, the size of the machine is almost halved.

6.2.7.1 Stack Turning Technology

In the stack turning technology, the mold rotation is performed with a horizontal rotary device in the form of a center plate.

Preforms are produced in the first parting plane. When the mold is opened, they remain on the side of the moving center plate. For a fully opened mold, the center plate is rotated 180° and placed in the second parting plane. After closing again, the second component is injected in the second cavity where the preforms are located on the center block.

When using stack-turning molds with $4 \times 90^\circ$ rotation, stations 2 (operator side) and 4 (non-operator side) can be simultaneously used for further production steps. For example, station 2 can be used for cooling the molded parts and station 4 can be used for removal by a robotic system. Both functions take place without affecting the cycle time. Alternatively, station 2 can also be used for mounting (in-mold assembly) inside and outside the system.

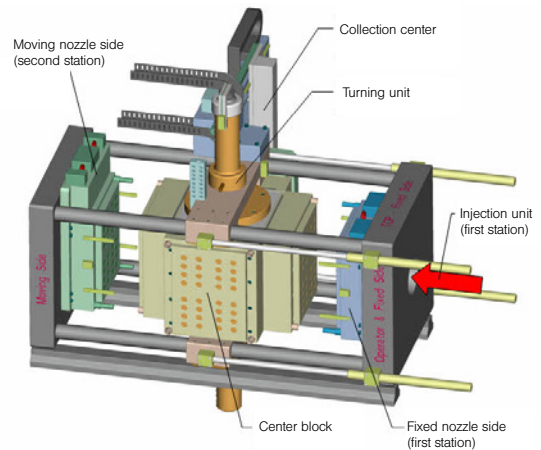

Figure 6.13 Principle of the stack turning technology (Source: FOBOHA)

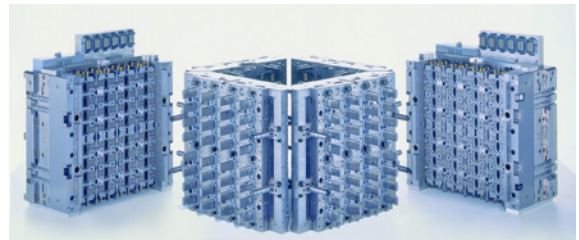

Figure 6.14 Stack turning mold (Source: FOBOHA)



When using the stack turning technology, the required clamping force is reduced by almost half. This mold technology is particularly useful for flat composite parts. In the $4 \times 90^\circ$ cube technology, the cycle time is reduced by approximately 25 % (compared to other methods) by simultaneous operations.

6.2.8 Tandem Mold

In the tandem molds, two molds are located behind the other. They are successively filled with plastic material and alternately opened in a cyclic manner.

In stack molds, the cavities are arranged one behind the other in several parting planes and are simultaneously filled with each shot; parts are simultaneously demolded after opening the mold.

With tandem molds, however, the parting plane opens cyclically staggered. This means that, while one mold half is cooling, demolding and re-injecting can be done in the other half. The dead time of the cooling is thus used for a second injection process. Since both mold halves run sequentially, different injection molded parts of one component family can be manufactured. Therefore, the injection molding machine must have a special program to determine the right amount of plastic provided for each parting plane.

Thick, identical parts with a long cooling time are also perfect for this technique.

An externally mounted locking system allows the cyclic alternating operation. The lock acts as a rack system. So it is possible, using an adapter plate, to convert two existing injection molds into a tandem mold.

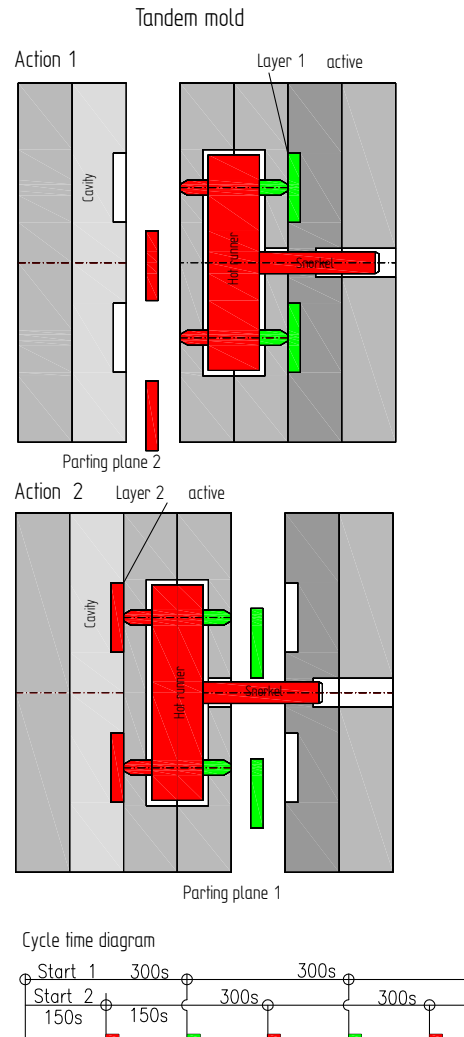

Figure 6.17 Principle of a tandem mold



With the tandem technology, the productivity can be doubled using a standard injection molding machine. Different injection parts of a component family are produced in cyclically displaced way.

6.2.9 Multi-Component Molds for Thermosets and Elastomers

In thermoset multi-component molds, hard-soft combinations are usually paired, although rarely are thermosets paired with thermosets. However, there are combinations with high temperature-resistant thermoplastics.

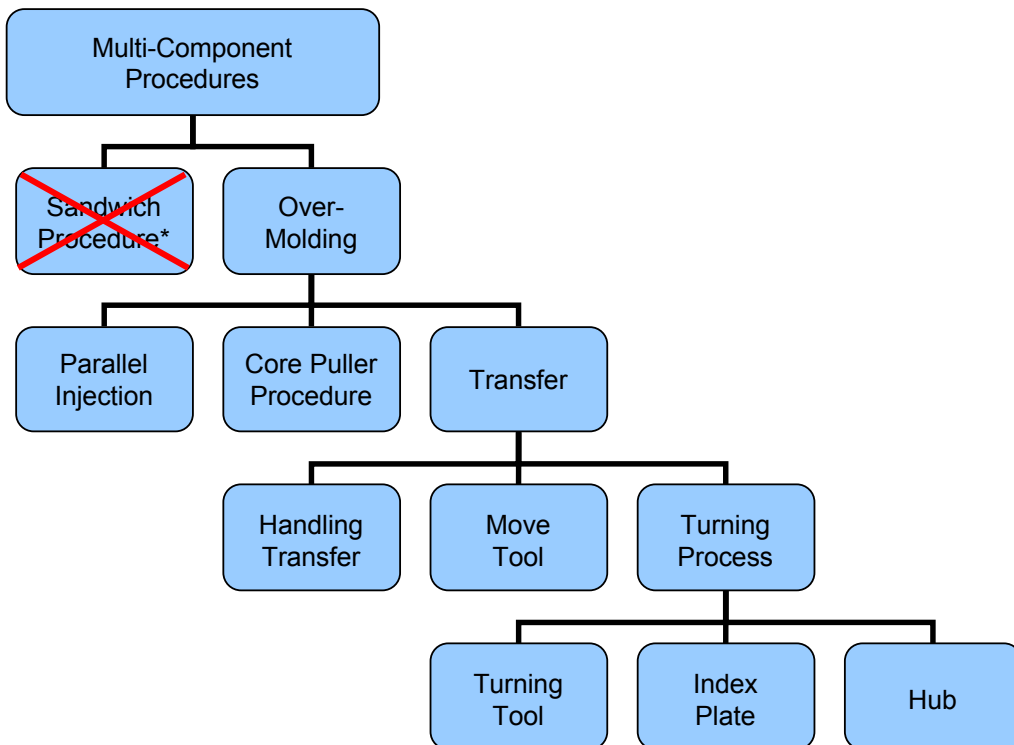

* For Thermoplastics only

Table 6.2 Multi-Component Processes for Thermosets and Elastomers