

■ 1.2 A Spider Supported Die Head

There are several names for this type of die, such as mandrel support die, ring support die, spider supported die, or spider die. The latter is the most commonly used term in the industry and will be employed here throughout this discussion.

This type of die is normally used for extruding PVC or similar types of thermally unstable materials. For other materials that are not so heat sensitive, such as polyolefins (LDPE, HDPE, and PP), polyamides, and many more, a spiral type of distribution is recommended because of its superiority in homogenizing the flow of plastic melt in the die head, as shown in Chapter 5.

In a spider die, a melt stream of plastic from the extruder enters the die head through the breaker plate or connecting ring (not shown in Figure 1.1) into a round channel. The spider cone or torpedo spreads the melt into an annular shape, as shown in Figure 1.1, before it is divided into several sections by the spider legs. Then, these melt sections are joined together by the converging angles of the connecting mandrel (04), the connecting ring (05), the die bush (07), and the mandrel (08). Finally, the melt is forced through a parallel annulus (more commonly known as a die land) between the mandrel and the die.

The term “die head” is used for the complete unit to distinguish it from the die or, as sometimes referred to, the bush. The die or bush is a part of the die head that forms the outside shape of the product to be extruded. To avoid any confusion, the term “die” will be used for the part 07 of the die head and “pin” for the mandrel (08).

The names of the die head parts used here are commonly known in the extrusion industry, and almost everybody involved in plastics processing is familiar with the function of these parts. Nevertheless, a brief description of these parts is given here, and more details are given in Chapter 3.

1.2.1 Flange Adapter

The flange adapter (01 in Figure 1.1) is sometimes known as flange connection and, as the name implies, on one side this part forms a connection to the extruder flange. On the other side it is attached to the spider, which holds the whole die head together. At the extruder end there is a recess to locate on the breaker plate or connecting ring.

The flange part is identical to the extruder flange and both the extruder flange and the flange adapter are clamped together with a clamp not shown in Figure 1.1. The melt from the extruder enters into the flange adapter from the breaker plate in the

form of strands, which are joined together into a round slug. In the case of a spider die head, the slug of melt is spread around the spider cone or torpedo, as shown in Figure 1.1.

The flange adapter normally has a heater and a thermocouple probe fitted to control the temperature of the material in this region. In some cases, a pressure transducer to monitor the pressure in the die head is also incorporated in this part. The design of the flange adapter varies with the design of the other parts of the die and the geometry of the extruder flange to which it is fitted, as can be seen in Chapter 3 and Chapters 5 to 13.

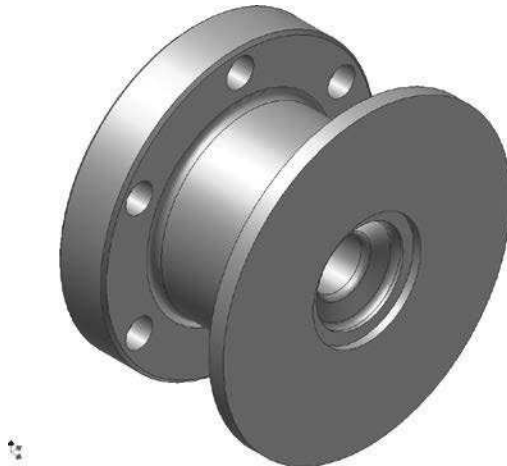

Figure 1.2 Flange adapter

1.2.2 Spider Cone or Torpedo

The spider cone or torpedo (02 in Figure 1.1) is a conical part attached to the inner section of the spider. It is used for dividing the flow of melt from a round slug to an annulus form, which is pushed through the spider channels. The design of this part is discussed in Chapter 3.

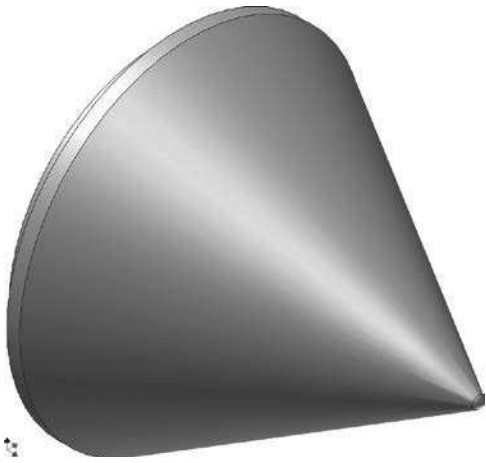

Figure 1.3 Torpedo

1.2.3 Spider

The spider (03 in Figure 1.1) is the heart of this type of die head. It is a bridge between the flange adapter and the connecting ring on the outside, and the torpedo and the mandrel or pin on the inside. More importantly, it divides the melt stream into channels around the spider legs. The melt is again joined by the compression in the connecting ring and the mandrel or pin. The inside and outside annular parts of the spider are kept together by the spider legs, the number of which varies between four and eight depending on the size of the die head. The gap between the outer ring and the inner section—in other words, the channel height—is designed to suit the output required, considering ease of manufacturing and a minimum residence time for the melt. A narrow channel increases the pressure in the die head and is difficult to machine and polish. On the other hand, a large section height increases the residence time and reduces the shear rate, resulting in degradation of the heat sensitive materials in this region. The shape of the spider legs is designed to divide the flow of melt stream and to make it join easily in the chamber between the connecting ring and the pin, as shown in Figure 1.4.

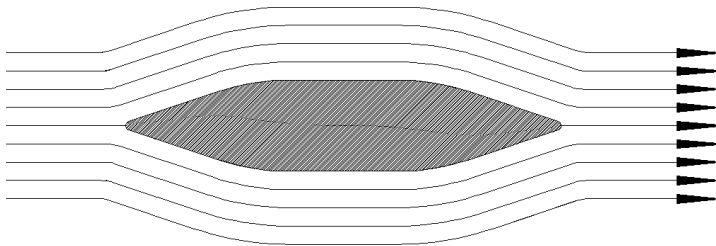

Figure 1.4 Section through spider leg

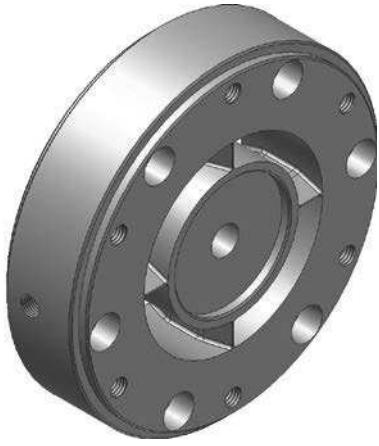

Figure 1.5 Spider

1.2.4 Connecting Mandrel

The connecting mandrel (04 in Figure 1.1) is connected to the inner section of the spider on one end and the pin is connected to it on the other end. The shape and dimensions of this part are dependent upon the shape and dimensions of the other adjoining parts, namely, the inside section of the spider and the diameter of the pin. The lengths of the connecting mandrel and of the corresponding connecting ring are designed to suit the characteristics of the material. These days, a spider die head is very rarely used for processing polyolefin materials like polyethylene and polypropylene. However, there are instances when, for very short runs and for economic reasons, a spider die head is used for processing these materials. In these instances, the lengths of the connecting mandrel and of the connecting ring are made considerably greater, to diffuse the melt disturbance caused by the spider legs and to minimize the flow lines.



Figure 1.6 Connecting mandrel

■ 3.10 Detailed Drawings

Having gone through the general principles of the spider die design, the detailed drawings prepared for manufacturing all the parts are shown below:

3.10.1 Die Bush

A detailed drawing of the die bush in Figure 3.18 shows all the common dimensions for all the sizes. The dimensions, which vary with each size of the pipe, are listed separately in Table 3.4. It should be noted that the back face of the die bush should be perfectly flat, to provide a good seal against the corresponding face of the outer connecting ring. The inside surface of the die bush should be highly polished and sectional changes should be blended with generous radii.

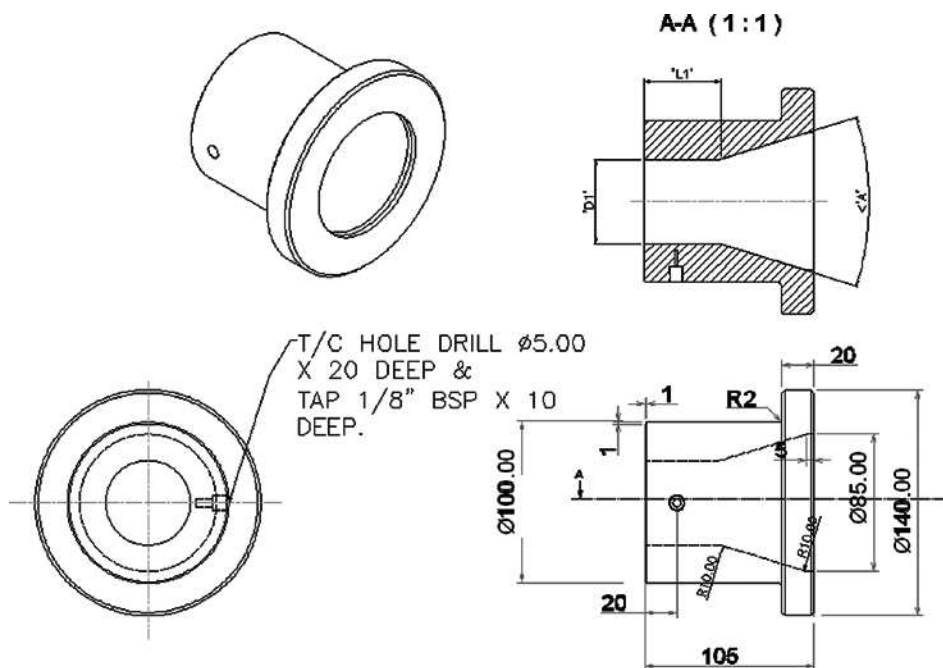

Figure 3.18 Detailed drawing of die bush

Table 3.4 Dimensions for Pipe Sizes in Section A-A

Pipe size [mm]	D1 [mm]	Land L1 [mm]	Angle A
50.00	52.50	58.35	42°37'
40.00	42.00	47.25	44°21'
32.00	33.60	37.80	44°54'
25.00	26.25	29.93	45°29'
20.00	21.00	23.78	45°33'

3.10.2 Pin

A detailed drawing of the pin in Figure 3.19 shows all the common dimensions for all the sizes. The dimensions, which vary with each size of the pipe, are listed separately in Table 3.5. The front end of the pin has a hexagon cut to fit a standard Allen key for tightening the pin to the connecting mandrel. The back face of $\phi 73.00$ mm fits against the corresponding diameter of the mandrel. Also note that generous radii to blend the sections should be used and the outer surface should be highly polished to eliminate the melt sticking to the surface.

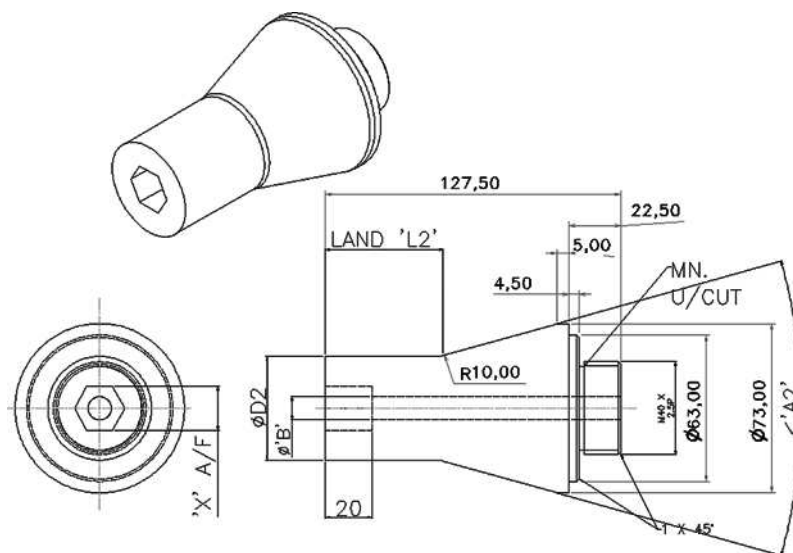
**Figure 3.19** Detailed drawing of pin

6

Monolayer Die for Tubes \varnothing 1 mm to \varnothing 6 mm

The principles of designing spiral mandrel dies for tubes and pipes are explained in Chapter 5, where a die for \varnothing 20 mm to \varnothing 50 mm pipe sizes was illustrated as an example. In this chapter, the design of tubes from \varnothing 1 mm to \varnothing 6 mm is given to cover a range of sizes, applications, and materials.

■ 6.1 \varnothing 1 mm to \varnothing 6 mm Fixed Center in Line Die

This die is used for medical tubes made from different types of polymers. As explained in the previous chapters, the starting point of die design is the design brief. Therefore, information about the design scope, product range, materials to be processed, output required, size of the extruder, etc. is collected as a starting point. After collecting this information, tables of product sizes, tooling sizes using convenient factors of draw down ratios, line speed calculations, etc. are compiled as in Table 6.1. From the tooling sizes a rough design of the die is made to get the geometry information for simulation purposes. From the simulation results, the design is corrected to suit the results and finalized to meet the customer requirements as close to the design brief as possible. This approach is repeated time and again for all the designs.

6.1.1 Design Brief

The information about the required die received from a particular customer is as shown in Table 6.1.

Table 6.1 Design Brief

1.	Product	$\phi 1.00$ mm to $\phi 6.00$ mm tubes.
2.	Product range (OD/ID)	$\phi 2.00/1.80$, $\phi 3.90/2.60$, $\phi 5.90/3.50$, and $\phi 6.00/4.30$.
3.	Wall thickness of each product	0.30 mm, 0.65 mm, 0.95 mm, and 0.85 mm.
4.	Material or materials if more than one	LDPE, HDPE, PVC, and Nylon 12. No specific supplier and grade were specified.
5.	Rheology data (relationship of shear rates vs. viscosities at different temperatures)	No information available. Data from literature is used.
6.	Thermodynamic data <ul style="list-style-type: none"> ▪ Density of each material ▪ Specific heat capacity ▪ Thermal conductivity 	Generic values for given materials used for simulation.
7.	Extruder details <ul style="list-style-type: none"> ▪ Type of extruder ▪ Screw diameter ▪ Required output ▪ Flange details ▪ Breaker plate dimensions 	<ul style="list-style-type: none"> ▪ Single screw ▪ 2.50 inches ▪ 45 kg/h ▪ Manufacturer's leaflet ▪ Manufacturer's leaflet
8.	Calibrator	Not available
9.	Cooling bath <ul style="list-style-type: none"> ▪ Dimensions ▪ Type: vacuum, spray, etc. ▪ Temperature 	Not available
10.	Haul-off <ul style="list-style-type: none"> ▪ Make ▪ Length ▪ Belt width ▪ Speed min/max 	Not available
11.	Cutter <ul style="list-style-type: none"> ▪ Make ▪ Length ▪ Speed min/max 	Not available
12.	Winder <ul style="list-style-type: none"> ▪ Make ▪ Diameter ▪ Speed min/max 	Not available

6.1.2 Draw Down Ratios and Tooling Sizes

Table 6.2 gives the product size and relevant tooling size.

Table 6.2 Draw Down Ratios for \varnothing 2–6 mm Tubes

	Tube designation	OD [mm]	ID [mm]	Wall thickness [mm]	Die ID [mm]	Pin OD [mm]	DDR	Layer thickness at material exit [mm]	Draw down ratio balance (DRB)
Single layer LDPE									
1	2	2.40	1.80	0.30	3.60	2.70	2.25	0.45	1.00
2	4	3.90	2.60	0.65	5.85	3.90	2.25	0.975	1.00
3	5	5.40	3.50	0.95	8.10	5.25	2.25	1.425	1.00
4	6	5.71	4.71	0.50	8.57	7.07	2.25	0.75	1.00
Single layer HDPE									
5	6	6.00	4.30	0.85	12.00	8.60	4.00	1.7	1.00
Single layer PVC (plasticized)									
6	6	6.00	4.30	0.85	12.00	8.60	4.00	1.7	1.00

Table 6.3 shows the calculations of the line speed for a given output.

Table 6.3 Calculations of Line Speed for Given Output

Material type	Material output [kg/h]	Density [kg/m ³]	Output volume [m ³ /h]	Tube OD [mm]	Tube ID [mm]	Area of annulus [mm ²]	Length of tube per hour [m/h]	Length of tube per minute [m/min]
HDPE	25.00	762	0.0328084	2.40	1.80	2	16577	276
HDPE	38.00	762	0.04986877	3.86	2.54	7	7516	125
HDPE	40.00	762	0.05249344	5.40	3.50	13	3952	66
HDPE	45.00	762	0.05905512	5.71	4.71	8	7216	120
LDPE	45.00	951	0.04731861	6.00	4.30	14	3441	57
PVC	35.00	1120	0.03125	6.00	4.30	14	2272	38

6.1.3 Design Procedure

Table 6.2 is used for starting the design from the tooling end and this information is used for the simulation as well. From the design brief in Table 6.1 it was evident that the output required by the customer is 45 kg/h (the maximum plasticizing

capacity of the extruder). This level of output is used for the largest size of tooling and smaller sizes of the tube would have less output, because of the high shear stress in the land area of the die annulus. Table 6.3 shows that a 45 kg/h output for a tube size of 5.71 mm in outside diameter and 4.71 mm in inside diameter will give a line speed of 120 m/min, whereas a tube of 2.40 mm in outside diameter and 1.80 mm in inside diameter will give a line speed of 276 m/min. It must be checked with the customer if their equipment would be capable of handling such a high line speed. The draw down ratio, which determines the tooling size and the level of output, can be changed from the simulation results, when the performance of the whole die is optimized.

From the above information, a rough design of the die is made to establish the initial dimensions of the die geometry. This die geometry along with the material information and the processing conditions are inserted into the simulation software to get the simulation results. The results are then checked and the design is changed to optimize the processing results in terms of the pressure drop in the die, shear rate, shear stress, residence time, etc., so that the ultimate die design meets the customer expectations and gives the most suitable results. This exercise, as explained in the previous chapter, is completed for all the sizes of the tubes and specified materials to be processed. The final design of the die for this particular customer is shown in Figure 6.1 and Figure 6.2.

The die shown in Figure 6.1 and Figure 6.2 is based on the 2 mm tube tooling as specified in Table 6.2. The die is designed for precision medical tubes, where the tooling is semi-fixed center; in other words, the pin is inserted into a concentric mandrel and it fits tightly on the taper in the mandrel. The die has a very slight radial adjustment on the die carrier (08), as shown in Figure 6.1. The whole idea is that once the small radial adjustment to get an even wall thickness of the tube is made, then the die adjustment should be locked in place. Any further tool changes should be made without the necessity of any adjustment to get an even wall thickness of the products. As the pin is inserted in the mandrel from the front, removing the pin for tool changing would be difficult unless the whole die is dismantled. To facilitate the quick tool changes, a pin pusher plug (12) and a pin pusher bolt (13) are placed in the die design. The winding in of the pin pusher bolt would push the pin pusher plug outward, which would release the pin from its taper in the mandrel. For inserting the new pin into the mandrel, the pin pusher bolt (13) is wound outward. For replacing the die, the die adjusting nut (09) in the front is removed first and then the die is pushed out with a slight movement of the melt from the extruder. In this way, a quick and easy tool changing is accomplished.

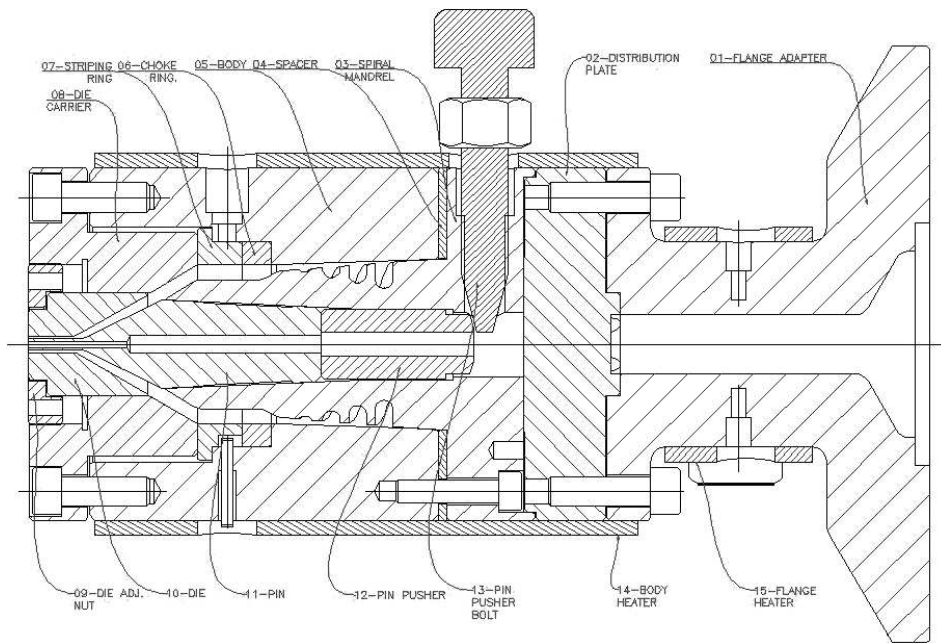

Figure 6.1 Sectional view of 2–6 mm tube dies, showing 2 mm pin and die in place and a mechanism for pushing the pin out

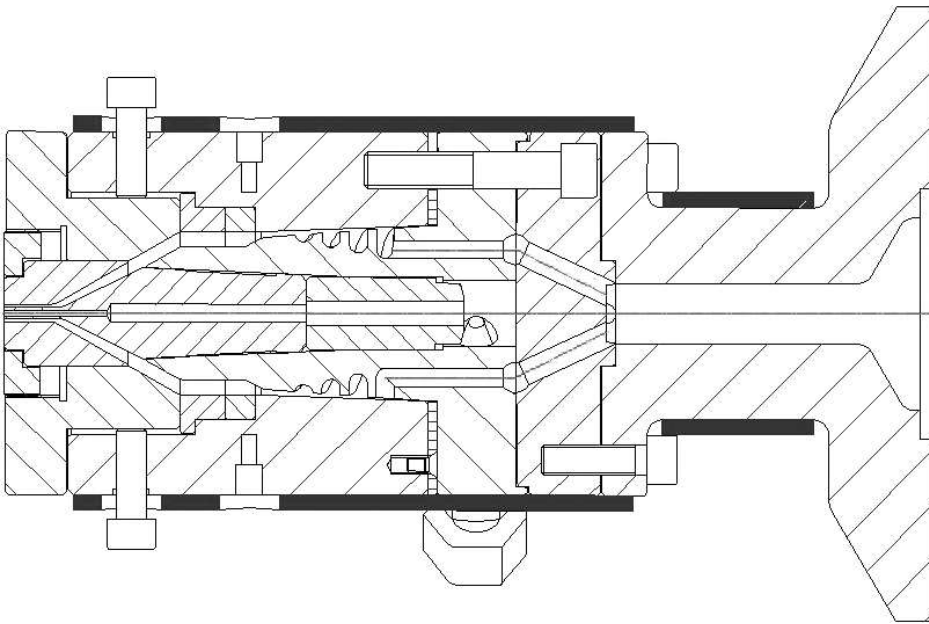

Figure 6.2 Sectional view of 2–6 mm tube dies, showing 2 mm pin and die in place and feed of melt into the spirals

6.	Thermodynamic properties	Thermodynamic properties obtained from the material manufacturers and supplied by the customer.
7.	Extruder	∅60 mm barrier screw extruder capable of plasticizing 400 kg/h of HDPE.
8.	Calibrators	Calibrators were supplied by the manufacturer of the vacuum bath and no further information was available.
9.	Cooling bath	Adequate vacuum bath and spray cooling baths facility installed.
10.	Haul-off	Suitable for the product range installed.
11.	Cutter	Does not concern the die design.
12.	Winder	Does not apply in this case, as the pipes would be cut to set lengths.

■ 9.2 Calculations of Draw Down Ratios for Tooling Sizes

The calculations of the inside diameters and wall thicknesses based on SDR 11, 17, and 26 and the sizes of the pins and dies using an adequate draw down ratio, along with the land length of the die, are given in Table 9.4.

Table 9.4 Draw Down Ratios and Tooling Sizes

1	2	3	4	5	6	7	8	9	10	11	12
	Pipe spec.	Pipe OD [mm]	Pipe ID [mm]	Wall thickness [mm]	Die ID [mm]	Pin OD [mm]	DDR	Layer thickness at die exit [mm]	DRB	Die land length [mm]	Max. output [kg/h]
SDR11											
1	140	140.00	114.55	12.73	154.0	126.00	1.21	14.00	1.00	210	370
2	160	160.00	130.91	14.55	176.0	144.00	1.21	16.00	1.00	240	380
3	180	180.00	147.27	16.36	198.00	162.00	1.21	18.00	1.00	270	400
4	225	225.00	184.10	20.45	247.50	202.50	1.21	22.50	1.00	338	400
SDR17											
5	140	140.00	123.53	8.24	168.00	148.24	1.44	9.88	1.00	148	340
6	160	160.00	141.18	9.41	192.00	169.41	1.44	11.29	1.00	169	360
7	180	180.00	158.82	10.59	216.00	190.59	1.44	12.71	1.00	191	380
8	225	225.0	198.53	13.24	270.00	238.24	1.44	15.88	1.00	238	400
9	250	250.00	220.59	14.71	300.00	264.71	1.44	17.65	1.00	265	420
10	280	280.00	247.06	16.47	336.00	296.47	1.44	19.76	1.00	296	430
11	315	315.00	277.94	18.53	378.0	333.53	1.44	22.24	1.00	334	450

Table 9.4 Draw Down Ratios and Tooling Sizes (continued)

1	2	3	4	5	6	7	8	9	10	11	12
	Pipe spec.	Pipe OD [mm]	Pipe ID [mm]	Wall thickness [mm]	Die ID [mm]	Pin OD [mm]	DDR	Layer thickness at die exit [mm]	DRB	Die land length [mm]	Max. output [kg/h]
SDR26											
12	250	250.00	230.77	9.26	300.00	276.92	1.44	11.54	1.00	173	380
13	280	280.00	258.46	10.77	336.00	310.15	1.44	12.92	1.00	194	400
14	315	315.00	290.77	12.12	378.00	348.92	1.44	14.54	1.00	218	415

Columns 1–10 in Table 9.4 are normal pre-design calculations; column 11 is the die land length, which in this case has been fixed as 15 times the layer thickness at the die exit. Column 12 is obtained from the die simulation results, which are explained later in the chapter.

■ 9.3 Initial Die Design

From the sizes of die and pin given in Table 9.4, initially the die is designed for a \varnothing 315 mm \times 17 SDR pipe using the die inside diameter of 378.00 mm, the pin outside diameter of 333.53 mm, and the land length of 334.00 mm. The design of the complete die is shown in Figure 9.1. The design of the initial die is slightly different to the previous dies discussed above. In this case, the die mandrel has 8 spirals, whereas in the previous dies 4–6 spiral designs were used. This is due to the physical size of the die. For the same reason, the inside of the mandrel and the pin are hollowed out to reduce the weight of the die, and internal heaters are fitted for ease of heating up the die at the start of the operation and also for a better temperature control. In Figure 9.2, the same die is shown with the tooling for \varnothing 140 mm \times 17 SDR pipes.

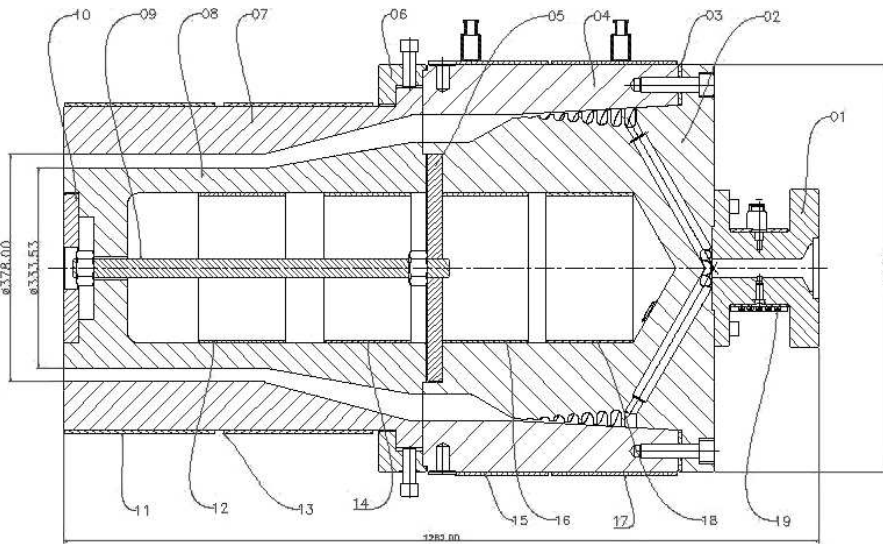

Figure 9.1 G.A. of Ø315 mm x 17 SDR die head

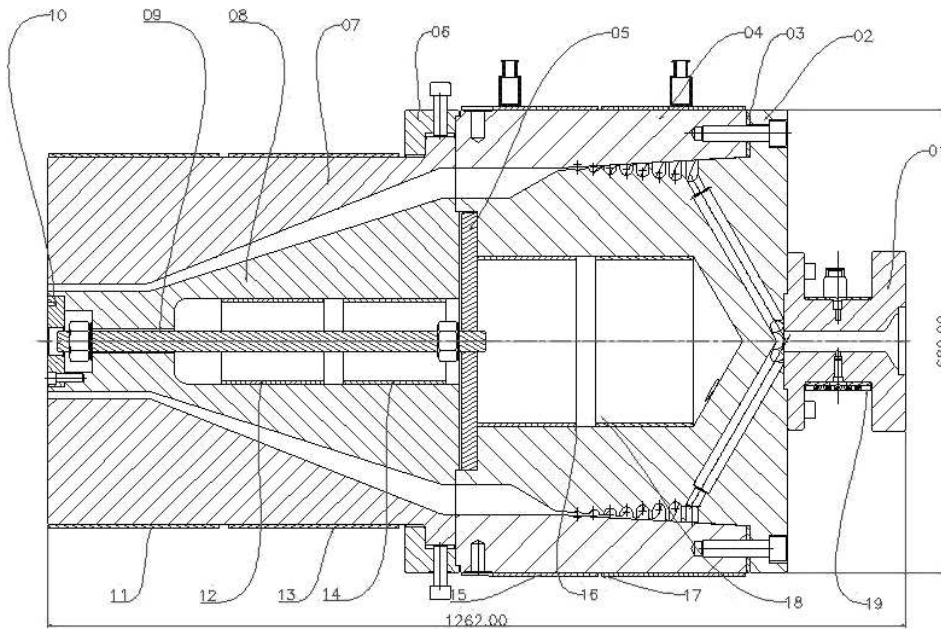

Figure 9.2 G.A. of Ø140 mm x 17 SDR die head

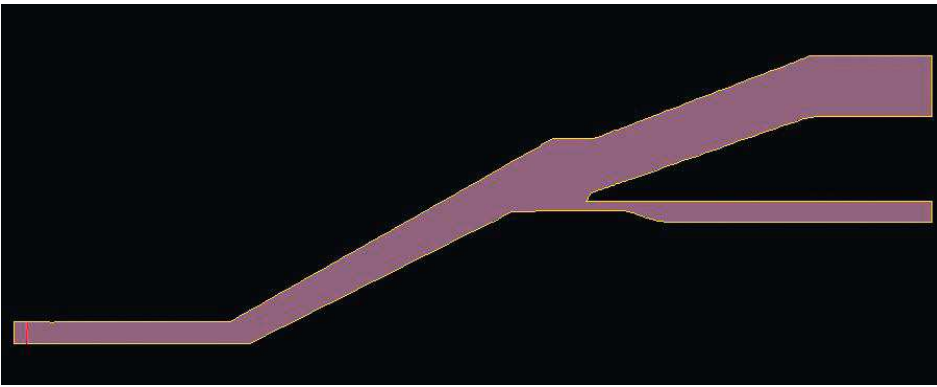

Figure 10.10 Velocity profile of two melt streams

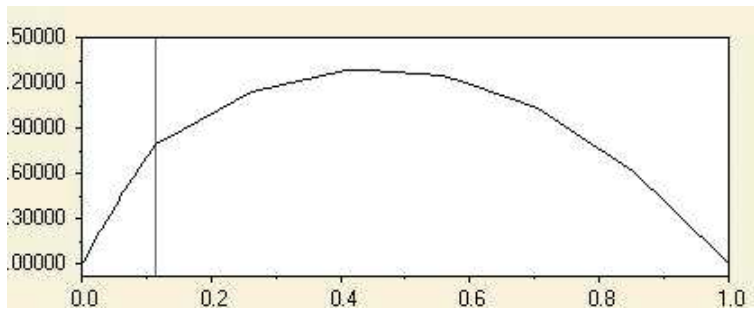

Figure 10.11 Graph of velocity profile of two melts close to die exit

10.2.1.2 Pressure Drop

Pressure is a primary variable calculated during the solution. As has been seen in the previous examples of dies, pressure drops from the maximum at the start of the melt stream to zero at the die exit. As shown in Figure 10.12, the maximum average value of pressure at the beginning of the section is 0.108 MPa and 0.00 at the die exit.

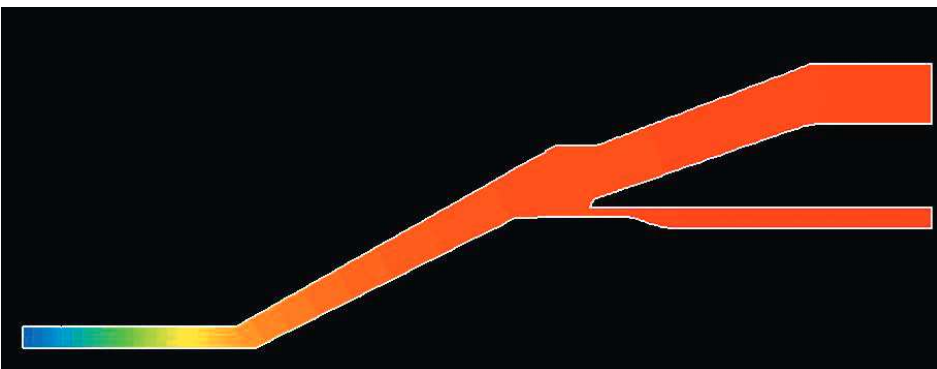

Figure 10.12 Pressure drop downstream

Figure 10.13 shows a line through the outer section, along which the pressure drop of the outer layer is plotted in the graph in Figure 10.14. The total pressure drop through this section is 0.10232 MPa, which is the value at the beginning of the section on the right hand side, and it drops to zero at the die exit, as shown in the graph of pressure drop along the line in Figure 10.14.

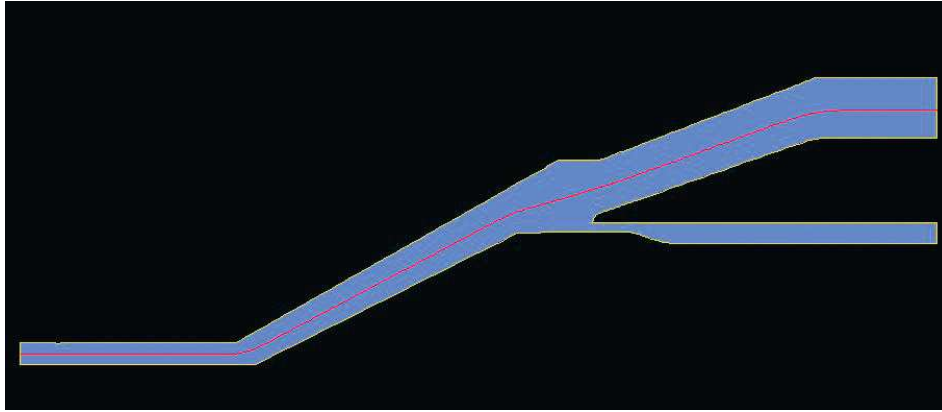

Figure 10.13 Pressure drop through the outer layer

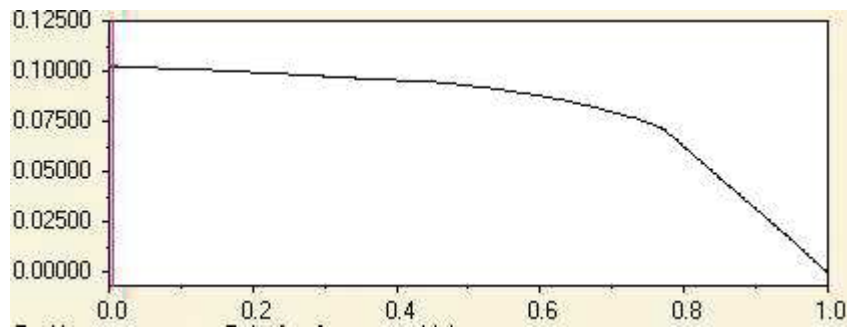

Figure 10.14 Graph of pressure drop through the outer layer

Similarly, Figure 10.15 and Figure 10.16 show the pressure drop along the line in the inner layer. The value of pressure drop through this section is 0.10770 MPa. This is slightly higher than for the outer layer because of the narrow section near the junction of the two melts, and as this melt in the inner layer joins the main stream it equalizes to the outer layer, as shown in Figure 10.15.

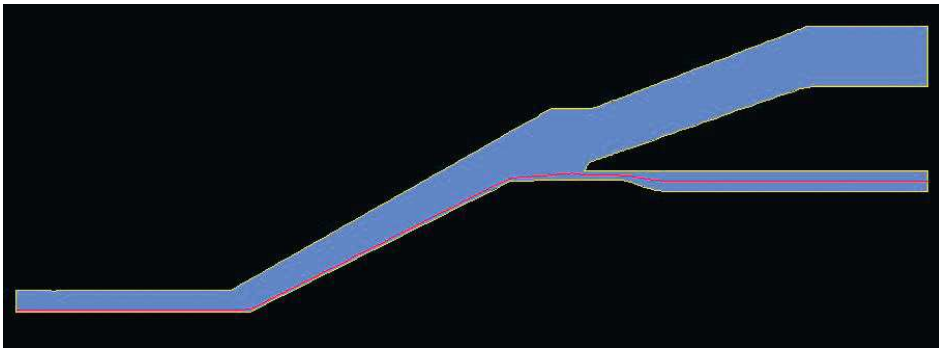

Figure 10.15 Pressure drop through the inner layer

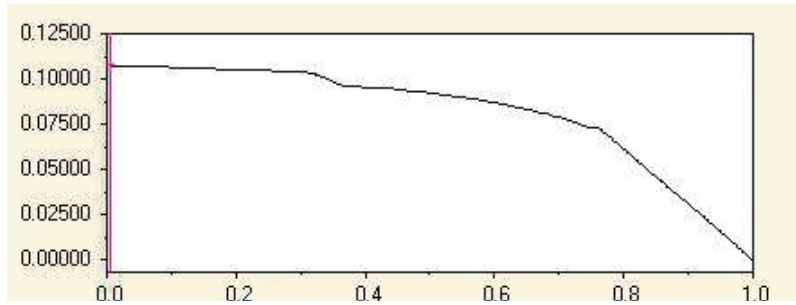

Figure 10.16 Graph of pressure drop through inner layer

10.2.1.3 Temperature

Figure 10.17 shows the temperature variations in the section. The set temperatures for the two melts entering the die and the die body temperature are 200 °C. The blue areas in the section in Figure 10.17 are at 200 °C, and the yellow and red areas are at higher temperatures.

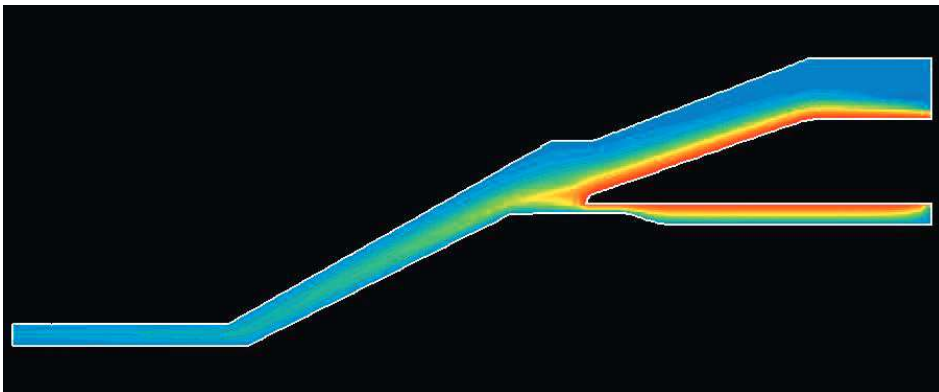

Figure 10.17 Temperature variations through the section

To investigate the extent of the variation in temperature near the wall of the outer layer, a line near the inside wall of the outer layer is drawn as shown in Figure 10.18, and the graph of temperature along this line is plotted in Figure 10.19. It can be seen from the graph that the temperature near the inside wall of the outer layer starts at 208 °C and rises to about 209 °C closer to where the two melt streams meet, and then it drops to 200 °C towards the die exit. For a material like HDPE this variation is not of much concern, since HDPE has a large window of processing temperature.

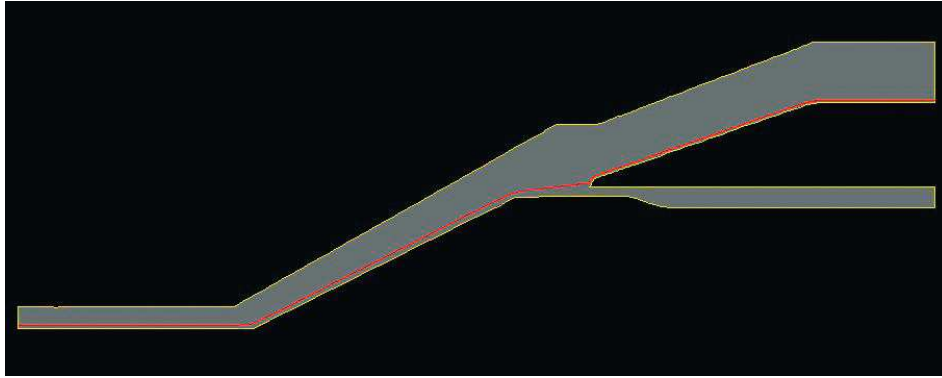

Figure 10.18 Line near the inside of outer layer

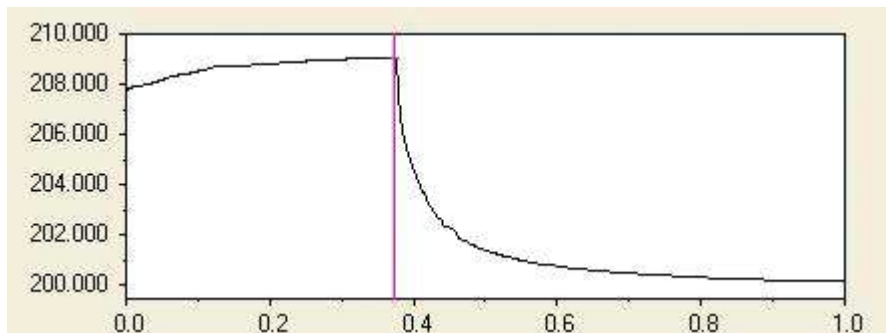

Figure 10.19 Temperature profile along the line in Figure 10.18

10.2.1.4 Shear Stress

The last variable to be checked for the die design is the shear stress. The physical meaning of this variable is that it shows the extent of shear stress generated during the melt flow. The value of shear stress is given in kPa. Figure 10.20 shows that the maximum shear stress is varying from -3.267 kPa to a maximum of 4.095 kPa in the red area of the section, which is in the die land region and closer to the outer

Index

Symbols

1.2083 steel [E337](#)
1.2311 (P20) steel [E333](#), [E335](#)
1.2312 (P20+S) steel [E336](#)
1.2316 steel [E335](#), [E337](#)
1.2344 (H13) steel [E333](#), [E334](#)
1.2738 (P20+Ni) steel [E336](#)
1.2767 (EN30B) steel [E334](#)
1.4462 steel [E338](#)
1.8509 (EN 41B) steel [E333](#)
Ø50 mm 11 SDR die [E167](#)
Ø50 mm 17 SDR die [E166](#)
Ø125 mm 11 SDR die [E166](#)
Ø125 mm 17 SDR die [E165](#)

A

above the distribution section [E167](#)
aluminum heaters [E260](#)
annuli [E133](#)
apparent values [E17](#)
average flow rate [E321](#)
axial flow [E237](#)

B

balanced dimensions [E318](#)
barrier materials [E297](#)
blown film [E223](#)
body [E131](#)
body heater [E131](#)
body temperature [E279](#)
bromides [E331](#)

C

cable covering [E12](#)
cable ducting [E263](#)
calcium carbonate [E331](#)
calculations [E32](#)
cartridge heaters [E260](#)
case-hardened [E332](#)
ceramic heaters [E260](#)
channel [E78](#)
channel depth [E73](#)
channel width [E73](#)
choke ring [E32](#), [E33](#)
coextrusion [E65](#), [E224](#), [E263](#)
coextrusion die [E239](#)
complete die [E318](#)
computer simulation [E39](#)
cone [E37](#)
convergence section [E82](#)
corrosion [E331](#)
corrosion resistant [E340](#)
corrosion resistant plating [E340](#)

D

data collection [E11](#)
dead spots [E65](#)
degradation [E65](#), [E220](#)
density [E23](#), [E176](#)
depth of spirals [E275](#), [E284](#), [E317](#)
design brief [E20](#), [E23](#), [E107](#), [E108](#), [E237](#), [E264](#),
[E298](#)
design of three-layer die [E302](#)
design scope [E127](#)

die [24](#)
 die-adjusting ring [131](#)
 die body [196](#)
 die bush [24, 28, 34, 131, 196](#)
 die clamp ring [196](#)
 die constant [54](#)
 die design [23, 25](#)
 die gap [75](#)
 die geometry [112, 244](#)
 die heater [131](#)
 die land [28](#)
 die rigidity [65](#)
 die simulation [176, 314](#)
 die trial [51](#)
 die wall temperature [60](#)
 dimensions of distribution [98](#)
 distribution section [113, 131, 167, 271, 282](#)
 distributor [197, 243](#)
 draw down ratio [25, 27, 127, 239, 299](#)
 draw down ratio balance [27](#)
 DRB [27](#)

E

elastic deformation [65](#)
 equipment [7, 18, 20](#)
 ethylene vinyl acetate [297](#)
 ethylene vinyl alcohol [297](#)
 EVAL [297](#)
 EVOH [297](#)
 experimental approach [51](#)
 extrusion screws [332](#)

F

factor of proportionality [54](#)
 feed balancing [317](#)
 feed ports [275](#)
 feed section [79, 112, 131, 167, 246, 276](#)
 final assembly [11](#)
 flange adapter [38, 131, 196](#)
 flange heater [131](#)
 flat sheets [23](#)
 flexible PVC [54](#)
 flow balancing [246](#)

flow in the channel [138](#)
 flow leakage [138](#)
 flow rate [132, 248, 279, 321](#)
 flow variation [92, 139, 180](#)
 fluid jacket heaters [260](#)
 fluorides [331](#)
 formulae [54](#)
 freezing temperature [176](#)
 fully hardened steels [333](#)

G

glass fibers [331](#)

H

hard chrome plating [340](#)
 Hastelloy® [331, 339](#)
 Hastelloy® C-276 [339](#)
 HDPE [147](#)
 heating of extrusion dies [260](#)
 heat treatment [332](#)
 Hooke's law [6](#)

I

Inconel® [339](#)
 initial die design [65](#)
 inside layer [248](#)
 instability [221](#)
 interfacial instabilities [65](#)
 internal heating [261](#)

L

land section [32](#)
 LDPE [143](#)
 leakage [65](#)
 low pressure losses [65](#)
 low residence times [65](#)

M

mandrel extension [311](#)
 mandrel height [71](#)

mandrel spacer [131](#)
 manufacturing methods [11](#)
 mass flow rate [60](#)
 material [206](#)
 material definition [320](#)
 material information [14, 16, 17, 135, 175](#)
 material residence time [13](#)
 materials for extrusion dies [1331, 331](#)
 material stagnation [207](#)
 materials used [298](#)
 mathematical calculations [32](#)
 melt flow [138, 179, 209](#)
 melt flow characteristics [13](#)
 melt flow rate [279](#)
 melt fracture [65](#)
 melt input temperature [60](#)
 melt stagnation [52](#)
 melt temperature [176, 279, 321](#)
 melt variables [279, 288, 321](#)
 mica band heaters [260](#)
 micro-duct [237](#)
 monolayer die [161, 191](#)
 multilayer [223](#)
 multilayer pipes [12](#)

N

nickel plating [340](#)
 nitrided steels [332](#)
 nitriding process [332](#)
 number of bolts [256](#)
 number of channels [74](#)
 number of feed ports [284](#)
 number of overlaps [170, 284, 317](#)
 number of ports [170](#)
 number of spirals [275, 284, 317](#)
 nylon (PA12) [160](#)

O

optimum output [139](#)
 output calculations [240, 266, 300](#)
 outside layer [271](#)
 overlaps [74](#)

P

PEEK [331](#)
 physical properties [16](#)
 pin [24, 41, 131, 196](#)
 polycarbonate [331](#)
 polyether ether ketone [331](#)
 polyvinylidene fluoride [297](#)
 power law exponent [54](#)
 pressure drop [13, 52, 54, 182, 207, 231, 248, 279](#)
 pressure grades [91](#)
 processing conditions [60, 83, 116, 127, 135, 176, 206, 248, 279, 288, 298, 320](#)
 product definition [13](#)
 product range [13, 14, 23, 107, 237, 298](#)
 product sizes [107](#)
 profiles [223](#)
 project definition [135, 175, 206](#)
 project planning [11](#)
 PVDF [297](#)

Q

quenched and tempered steels [335](#)
 quick tool changes [110](#)

R

range of similar products [12](#)
 redistribution [65](#)
 reference diameter [170, 274, 283, 316](#)
 relaxation chamber [29, 31, 73](#)
 relaxation zone [309](#)
 residence time [13, 52, 220](#)
 results of variables [177, 207](#)
 rheological [14](#)
 rheology [15, 20, 52](#)
 rheology data [23, 135, 175, 238, 298](#)
 rheometer [32](#)
 ring feed system [170](#)

S

SDR [163](#)
 sealing section [172](#)
 section above the distribution [131](#)
 section above the spirals [80, 199, 324](#)
 section past the spirals [276](#)
 selection of die materials [111](#)
 shark skin [221](#)
 shear rate [13, 16, 17, 52, 207, 321](#)
 shear stress [13, 15, 16, 52, 207, 234, 279, 321](#)
 sheathing [224](#)
 side-fed die [224](#)
 simulation [76, 206](#)
 simulation of materials flow [111](#)
 simulation results [17, 177](#)
 size of the extruder [19](#)
 solving problems [19](#)
 speciality steels [336](#)
 specific heat capacity [23, 176](#)
 specific heat of fusion [176](#)
 spider [35, 41, 47](#)
 spiral depth [170](#)
 spiral die [165](#)
 spiral height [72, 170, 274, 316](#)
 spiral mandrel [131, 196](#)
 spiral mandrel die [165](#)
 spiral mandrel distributors [165](#)
 spiral radius [170](#)
 spirals [244](#)
 standard dimension ratio [163](#)
 STAVAX® ESR [338](#)
 striping [253](#)
 surface hardness [332](#)
 swell phenomenon [25](#)

T

temperature change [182, 207](#)
 temperature profile [234](#)
 temperature variation [233](#)
 tempering [333](#)
 thermal conductivity [23, 176](#)
 thermal properties [15](#)
 thermodynamic [17, 18](#)
 thermodynamic data [23](#)
 thermodynamic properties [52, 135, 175, 238, 298](#)
 third layer [289](#)
 three-layer crosshead die [297](#)
 three-layer die [263](#)
 tightening torques [259](#)
 tooling [242](#)
 tooling section [15, 133, 268, 302](#)
 tooling sizes [299](#)
 torpedo [33, 37, 47](#)
 type of extruder [19, 20](#)

V

values of PN [191](#)
 velocity [321](#)
 velocity profile [228](#)
 viscoelastic behavior [32](#)
 viscosity [15, 16, 17](#)
 volumetric flow rate [221](#)

W

wall thickness [4, 23, 24, 237, 298](#)
 wear [331](#)
 wear resistant [332, 340](#)
 wire covering [12](#)
 work harden [331](#)