

1

Introduction

This book presents information about snap-fit technology in a logical format for learning and understanding. Once the reader understands snap-fit technology, this book will provide design guidance as a reference handbook.

The book has multiple purposes:

- Teach the reader a practical method of thinking about and using snap-fit technology.
- Be a comprehensive product development reference for snap-fit solutions.
- Provide a place for readers to record their own snap-fit lessons-learned.
- Provide guidance for managers wishing to develop a sustainable culture of snap-fit expertise in their product development organizations.

Any scientific discipline has a need for a specific language for describing and summarizing the observations in that area [1].

Experience without theory teaches . . . nothing [2].

This book captures both the *language* and *theory* of snap-fits in a unique knowledge model that explains the snap-fit interface as a system. Readers with some snap-fit experience will find this model allows them to integrate their existing knowledge with new snap-fit information. Snap-fit novices will find the model makes understanding snap-fit technology easier. All readers will learn a practical way of thinking about and, most importantly, *using* snap-fits in product applications.

The task of developing snap-fits generally falls on product engineers, designers, and developers (referred to collectively in this book as *developers*). A developer with little or no snap-fit experience can quickly find calculations in the literature for determining snap-fit lock behavior. However, next they will learn that while calculating lock feature behavior is important, it is not enough. Their learning will then go through a trial-and-error process during product testing and redesign. Sometimes design flaws are not discovered until a product is in the consumer's hands. In any case, product development through trial-and-error is time-consuming and potentially quite expensive. We want to avoid that.

Product developers may have access to someone with snap-fit experience, but their usefulness is generally limited to what they too have learned through trial and error.

A couple of bad experiences with snap-fits may cause a product developer or an entire organization to decide that snap-fits are not worth the trouble. This is unfortunate; to remain competitive, companies must utilize all possible design strategies. To ignore snap-fits as a legitimate attachment option is a mistake.

Reasons for using snap-fits include appearance, packaging, and tamper resistance. However, the most compelling reason is economic. When snap-fits replace loose fasteners and the associated assembly tools and tightening operations, significant cost savings are possible.

Snap-fit attachments are a *system*. It's time to start treating them that way.

The increasing use of snap-fit technology parallels the growing use of plastics in products. Processing technologies have made production of complex shapes economically feasible. The advantages of ease of assembly and disassembly and the ever-increasing engineering capabilities of plastic materials now make snap-fit technology a serious candidate for applications once considered the domain of threaded or other mechanical fasteners.

The growth and advancement of rapid-prototyping technology has made the creation of accurate part models possible. These models provide early and meaningful evaluation of attachment concepts for more potential snap-fit applications.

While toys and small appliances have long made extensive use of snap-fits, the technology is now applied in virtually every product field including medical devices, automotive components, small and large appliances, electronics, and numerous consumer goods. Snap-fit technology is also being extended to structural applications [3-5].

Although commonly associated with plastic parts, snap-fits are also possible in metal-to-metal and plastic-to-metal applications. Keep this in mind as you read this book, and look for opportunities to use snap-fits in metal as well as plastic applications.

■ 1.1 Reader Expectations

This book is not what a reader is likely to expect in a book about snap-fits.

Because snap-fit technology has traditionally been viewed as nothing more than lock feature calculations, readers may expect this book to be full of equations for calculating snap-fit lock behavior. *It is not.* This book includes those calculations but there is much more to snap-fit application development than just calculations.

Material property and part processing information is presented here only to the extent needed to support understanding of the snap-fit development process. Many excellent books and references are available on those topics and this book would serve no purpose repeating that material.

The reader must understand that experience with threaded fasteners, the most common method of mechanical attachment, is not transferable to understanding or developing snap-fit attachments. New ways of thinking about the attachment must be learned. There is more discussion of this subject in the next section.

The reader should expect to acquire a deep intuitive or gut-level understanding of snap-fits. You will learn how to *think* about snap-fits to solve routine as well as unique snap-fit design issues during product development.

After studying some sophisticated snap-fit applications, one cannot help being impressed and maybe intimidated. It's OK to be impressed, but do not be intimidated. With the knowledge in this book and through experience, every reader will gain the knowledge needed to create world-class snap-fits.

The reader will find that, occasionally, information may appear more than once in different chapters. This is intentional; information is repeated because of its importance or

because it is being presented in a different context. Sometimes repetition is unavoidable because of the multiple interactions between elements and design concepts, and repetition is needed to ensure clarity and understanding of these interactions.

■ 1.2 Harmful Beliefs

Seven common beliefs about snap-fit technology are described here. In this book, you will learn why these beliefs are wrong and how these beliefs interfere with developing cost-effective and reliable snap-fit attachments. You, the reader, may hold some of these beliefs. You will also find that your peers, management, and suppliers may likely hold some of these beliefs as well. Some of these beliefs will manifest themselves as a fear of using snap-fits. Other beliefs can have the opposite effect, leading to the misconception that snap-fits are so simple they require little or no thought at all. The harmful beliefs are:

- **The battery cover syndrome.**

Most people are familiar with snap-fits thanks to their usage on common applications like remote control battery covers and toys. This can lead to two common and erroneous beliefs: (1) Snap-fits are only appropriate for simple or noncritical applications and (2) Snap-fits are trivial and easy to design.

- **Snap-fits are a materials technology.**

Because snap-fits are generally found in products made from polymers, there is a belief that polymer experts (including resin suppliers) can be the design resource for snap-fit applications. Polymer experts should certainly be a primary resource for material properties, but they should not necessarily be expected to be the primary source for product design. Many polymer suppliers do have a wealth of experience in product design, and there is no reason not to use them as a secondary resource. Even when a supplier is, by contract, providing the primary design work, it is still up to you, the customer, to ensure the design, including the snap-fits, is done properly.

This author would be very pleased to find the attachment level design principles appearing in plastic supplier design guides, but it hasn't happened yet.

- **Cantilever hooks represent snap-fit technology.**

The cantilever hook style locking feature seems to be everywhere, but it is not representative of all snap-fit technology. When asked to create a snap-fit attachment, many developers will default to this style because of its familiarity. Many other lock feature styles exist as attachment options *and are often a better choice*.

- **All I need to do is design the locking feature.**

A snap-fit attachment is an interface system and it must be developed as such. Many well-designed lock features fail to perform as expected because the systemic aspects of the part-to-part interface have been ignored.

- **Experience in other fastening methods transfers to snap-fits.**

No, that experience does not transfer. Snap-fit attachments are *fundamentally different* from all other fastening methods. New and different knowledge is required to understand and apply snap-fit technology to product development.

- **Every snap-fit application is a new invention.**

With snap-fits, the same fundamental rules of design are true for a finite number of common part-to-part combinations. Once those basic combinations are understood, a new application can be designed around existing and well-understood basic principles and rules.

- **I can do the attachment after I do everything else.**

The attachment concept must be developed simultaneously with the parts that are being attached. Certain design details can wait until later, but getting the basic snap-fit concept right early in the development process is critical to the attachment's success.

These beliefs are discussed in more detail in Chapter 15.

■ 1.3 Snap-Fit Technology

A snap-fit is the entire part-to-part interface.

The terms *snap-fit* and *integral attachment* are often used interchangeably because snap-fit lock features are molded or formed as integral features of parts. To avoid confusion, we will stick with the term *snap-fit*.

In the traditional meaning of the term, snap-fit referred to only the lock features.

In this book, the term snap-fit refers to the *entire attachment interface* (see Fig. 1.1), of which the lock feature(s) is only one element.

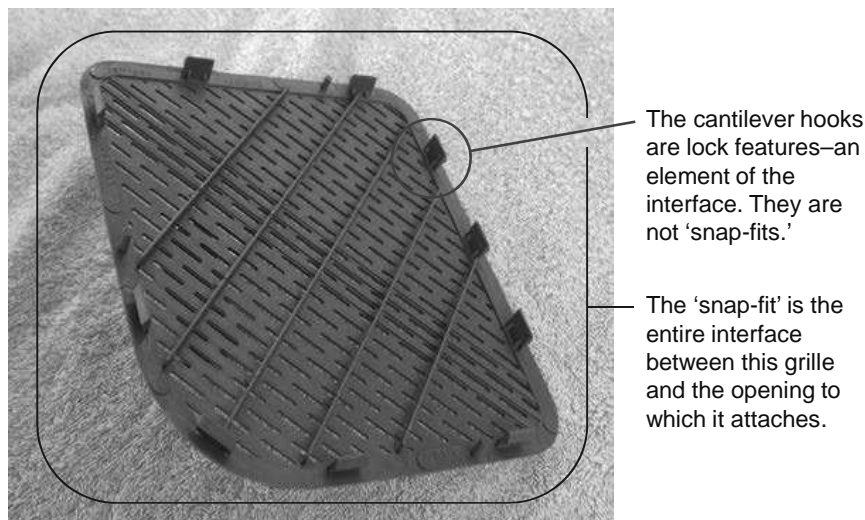
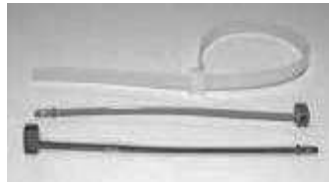

Figure 1.1 A snap-fit is the entire attachment interface, not just the locks

Snap-fit applications range from the very simple to the very complex. Some snap-fits hold one part to another and little or no force is transmitted across the interface. In other applications, snap-fit attachments must be strong and extremely reliable, see Fig.1.2.



Hairclip



Tie-straps



Container



Link assembly for overhead conveyor



Tail-lamp assembly. The lens and bulb carrier both attach to the reflector.



Detail of reflector from tail-lamp assembly showing part complexity

Speaker assembly; this is a large, high-mass speaker used in an automotive application.



Figure 1.2 Snap-fit application examples

■ 1.4 Snap-Fits and Loose Fasteners

A snap-fit is different from loose threaded fasteners and other mechanical or chemical attachment methods in that it requires no additional pieces, materials, tools, or operations to carry out the part joining function.

The choice between snap-fits or loose fasteners is a major decision point in product development. Chapter 3, Section 3.3, discusses this decision in depth. Neither snap-fit nor threaded fastener technology is inherently good or bad; both have their place in product design based on informed decisions about the best attachment for the application.

Without intending insult to threaded fastener technology (the author spent 30 years as a threaded fastener subject matter expert), we can think of a threaded attachment as a *brute force* approach to connecting parts. The fastener's strength makes it easy to ignore or forget some of the finer points of interface design and behavior. A retention problem can often be fixed by simply using a higher strength material for the fastener, tightening it to a higher clamp load, specifying a larger fastener, or adding more fasteners. Indeed, a major advantage of a loose fastener is that its strength is independent of the joined components. This is not the case with snap-fits.

With a snap-fit application, we do not have the luxury of selecting a fastener material and strength that is independent of the joined components. Most of the time, material selection is driven by other application considerations, not by attachment requirements. One must work with the material(s) selected for the parent components. Processing requirements can also restrict design options because the attachment features must be formed with the part. The subtleties of interface design and behavior must be well understood and reflected in the design. A snap-fit application, therefore, must be a more *elegant* method of attachment than a bolted joint.

Experience with threaded fasteners **does not** transfer to snap-fits.

■ 1.5 Snap-Fits as Interface Systems

The key word here is *system*. In any assembly of individual components, part-to-part attachment occurs across an interface. A successful product development process must treat that interface as a system and it must be developed as the parts themselves are being developed. To start, we will define two major areas of snap-fit technology: *feature level* and *attachment level*.

Other comments have mentioned the *jargon* in the ALC, with the term having a negative connotation. To go back to the statement at the beginning of this chapter: *Any scientific discipline has a need for a specific language for describing and summarizing the observations in that area* [1]. Before the ALC was created, there was no consistent and organized terminology and no structured design knowledge for snap-fit technology. Consistency and organization are necessary for accurate communication, understanding, and growth of a subject.

To draw a historical parallel: In the 1700s, Carl Linnaeus, a Swedish botanist and physician, developed his revolutionary taxonomy for classification of species. The organization it provided to the complex plant and animal kingdoms contributed to the proliferation of scientific discovery that followed [6]. Scientists finally had a language and a structure for organizing and understanding their subjects. Linnaeus' classification scheme remains in use today.

■ 1.7 Using This Book

After reading this chapter, if you have not already done so, go back and read the preface to the first edition. This will help you understand the foundations and evolution of the attachment level technology and the how and why of this book.

Figure 1.5 shows the book's chapters. They are organized around the ALC shown above in Fig. 1.4. Most chapters conclude with a summary of important points introduced in that chapter. Refer to these end sections as quick reviews of the chapter content or use them as an overview before reading the chapter.

Blank space for recording notes is provided at the end of most chapters.

Engineering managers
should read
Chapter 15.

Chapter 1 – Introduction

You are here.

Chapter 2 – Key Requirements

Key Requirements are high-level technical requirements shared by all fundamentally sound snap-fits.

Chapter 3 – Introduction to the Snap-Fit Development Process

This introduction to the development process supports discussions in the chapters that follow. Chapter 10 describes the process in more detail.

Chapter 4 – Descriptive Elements

These are generic terms and concepts for describing a snap-fit application. They also support transfer of snap-fit knowledge between applications.

Chapter 5 – Physical Elements: Locators

Styles of locator features are described. Locators are the strong, inflexible constraint features in an interface.

Chapter 6 – Physical Elements: Locks

Styles of lock features are described in Chapter 6, and their strengths and weaknesses are discussed. Locks are the latching features in an interface.

Chapters 7 and 8 explain important concepts related to the physical elements, locators, and locks, which are introduced in Chapters 5 and 6.

Chapter 7– Lock Strength and Decoupling

Decoupling explains why some lock features are far superior to others for assembly and part retention.

Chapter 8 – Constraint

The most fundamental of the key requirements. Constraint describes and quantifies how the joined parts are properly positioned and latched together.

Chapter 9 – Physical Elements: Enhancements

Enhancements are physical features or attributes of other features in the interface. They are often the kind of design tricks or details an experienced developer may know to use but the novice will not.

Figure 1.5 Book contents

Chapter 10 – Applying the Snap-Fit Development Process

The snap-fit concepts, elements and design rules described in the previous chapters are applied to product development.

Chapters 11, 12, and 13 discuss feature analysis topics.

Chapter 11 – Feature Design: Material Properties

The material properties used in feature calculations are explained.

Chapter 12 – Feature Design: Rules of Thumb

Some general design rules are useful for preliminary lock feature development.

Chapter 13 – Feature Design: Calculations

Beam-based lock calculations are discussed in detail, and modifications to the classic beam calculations are introduced. Calculations for other lock styles are also provided without detailed discussion.

Chapter 14 – Diagnosing Snap-Fit Problems

Just as it guides development, the ALC provides the basis for diagnosing common snap-fit application issues.

Chapter 15 – Gaining a Competitive Advantage in Snap-Fit Technology

An organization can go beyond individual snap-fit expertise and create a sustainable culture of competence to gain a competitive business advantage.

Appendix: Resources – Sources of additional snap-fit information and data.

Figure 1.5 Book contents, continued

1.71 Sample Parts

Snap-fits are a highly spatial and visual topic. The best way, by far, to understand them is to hold parts in your hands. The reader should have snap-fit applications available to study for reinforcement of the design rules and concepts presented here. As you read, use these parts to identify and understand the principles and rules being discussed.

Snap-fit applications are everywhere: find them in toys, electronics, small appliances, vacuum cleaners, etc. They can be found in products as diverse as patio lamps, chemical sprayers, slot-car tracks, and toilet tank shut-off valves. An excellent product for studying a wide variety of snap-fit applications are the old Polaroid One-Step® cameras. They are no longer in production but may be found online and at garage sales. They are 100% snap-fit and the variety and cleverness of the attachments is impressive.

2

Key Requirements

Chapter 2 introduces the *key requirements* for snap-fit applications. These are common technical characteristics shared by all fundamentally sound snap-fits and satisfying them is the goal of snap-fit application development. These key requirements are the top level of the Attachment Level Construct (ALC), see Fig 2.1.

Meeting specific application requirements like durability, reliability, quality, and ease of assembly will be difficult, costlier, or impossible unless the key requirements are satisfied.

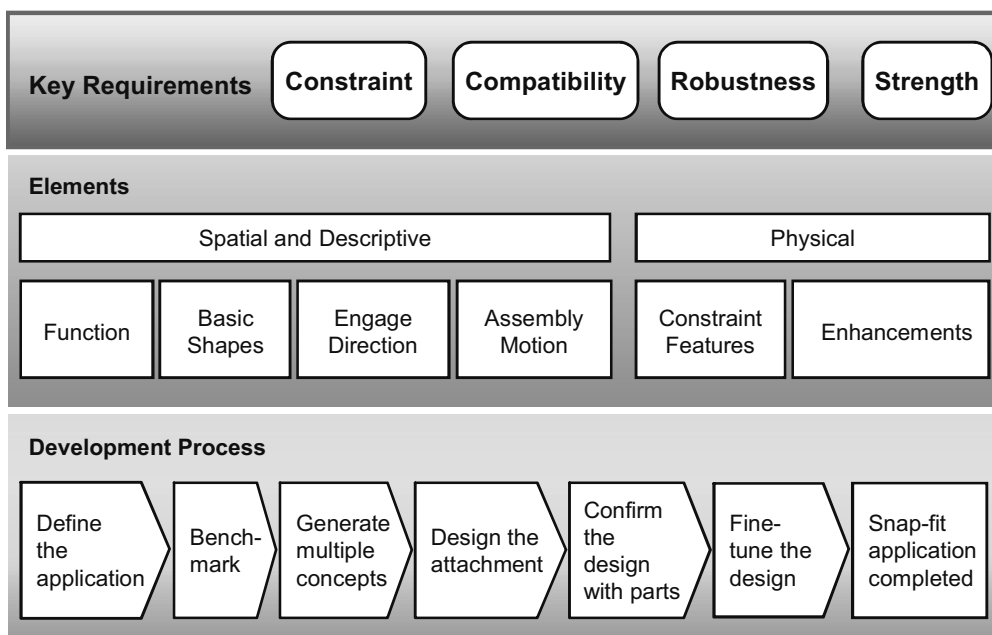

Figure 2.1 Key requirements in the Attachment Level Construct (ALC)

■ 2.1 Constraint

Proper *constraint* is the foundation for a good snap-fit attachment. This is a brief introduction; Chapter 8 discusses the subject in detail.

In a Cartesian coordinate system, linear motion of a free object in space is described by \pm translational movement along the three axes and \pm rotational movement around the axes. To fix an object in a given location, each of those motions must be *constrained*.

In any mechanical attachment, one part is held in a specific location to another part across an interface. We'll refer to them as the *mating part* and the *base part*, respectively, see Fig. 2.2.

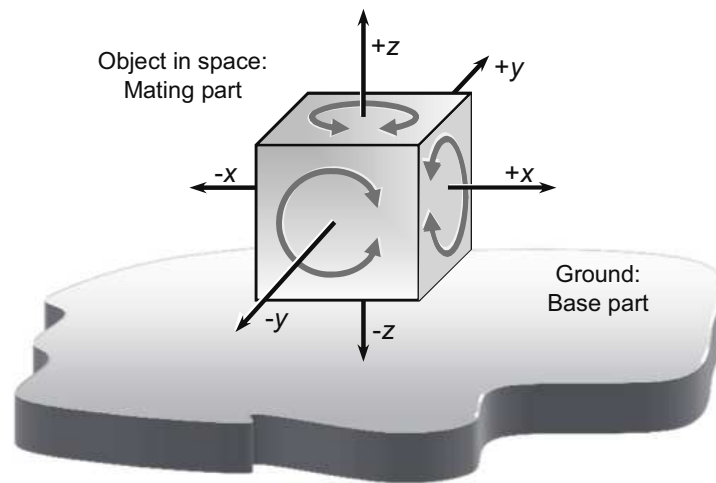

Figure 2.2 Mating and base parts and a Cartesian coordinate system

In threaded fastener joints, friction due to clamp-load across the interface and the fastener's tensile strength provide much, if not all of the constraint to hold the parts together. With threaded fasteners, we usually do not even need to think about constraint, it just happens.

In a snap-fit attachment, there is no real clamp-load. Relative movement of the mating and base parts is prevented by interacting features designed into the parts (Fig. 2.3).

Locating features or *locators* provide positioning while locking features or *locks* latch the mating and base parts in their located relationship. Relative movement is controlled and all forces on the parts are transmitted across the interface through the locator and lock constraint features.

Locks and locators are used in *constraint pairs*. In a locator pair, a locator engages another locator. In a lock pair, a lock engages a locator, although there can be exceptions to this rule.

Success in satisfying the other key requirements depends on a properly constrained snap-fit. Because it describes part-to-part and feature interactions, *constraint* is strongly tied to the concept of a snap-fit as a system.

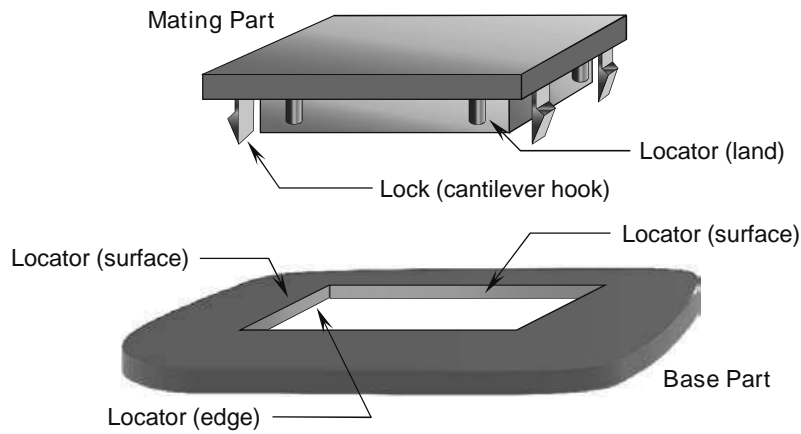

Figure 2.3 Constraint features

■ 2.2 Compatibility

Compatibility is harmony between the elements of the snap-fit interface. Some combinations of part shapes, constraint features, assembly/disassembly motions, and directions can cause difficult assembly or feature damage and should be avoided.

Incompatibility can be a subtle mistake, not easily recognized until symptoms and problems occur. One reason for this may be that decisions affecting compatibility can be made at different times during the development process, sometimes by different individuals.

For example, the door handle application in Fig. 2.4 requires a tipping motion for assembly. But, with this motion, the rigid lugs cannot deflect for engagement with an edge on the mating surface. This causes assembly difficulties in the form of high assembly force, a high scrap rate due to broken lugs on the handles, and the possibility of handles with damaged, but not fully broken lugs, not being discovered until they literally end up in the customer's hands.

In this design, the lug style and locations are not compatible with the assembly motion. This can be fixed by redesigning and relocating the lugs.

■ 6.3 Cantilever Beam Locks

Locks based on cantilever beams are by far the most common lock style. Because they are so common, we will spend more time on them than on the other styles. For the same reason, they are sometimes used by default throughout this book when a lock is needed to complete an example or an illustration. In a real application, another lock style may be preferred.

However, despite their frequency in product applications, as well as in illustrations, examples in this book, and in the literature, never forget that *cantilever hooks*, one of the beam-based lock styles, are the *least preferred* lock for many applications. This topic is discussed later in this chapter as well as in other parts of the book.

In cantilever locks, the deflecting member is a beam. The most common beam shapes have a rectangular section and may be straight or tapered in length or width or both.

Analysis of beam behavior for assembly and separation is based on classic bending equations for a cantilever beam fixed at one end. Exceptions are a beam fixed at both ends and the nonreleasing trap style lock which is analyzed as a column in compression. The purpose of analysis is to determine the beam's bending force and maximum strain. Beam bending force is then used in assembly and separation behavior calculations. These results determine the lock's final dimensions.

Common cantilever lock configurations use beams similar to those in Fig. 6.4 and have a rectangular section. Other sections are possible. Beams having a gently curved section are sometimes used in a circular arrangement of locks. Sometimes this circular arrangement of cantilever hooks is incorrectly called an annular lock, see Section 6.6 for a discussion of annular locks.

The retaining member is selected independently of the deflecting member.

Beam shapes

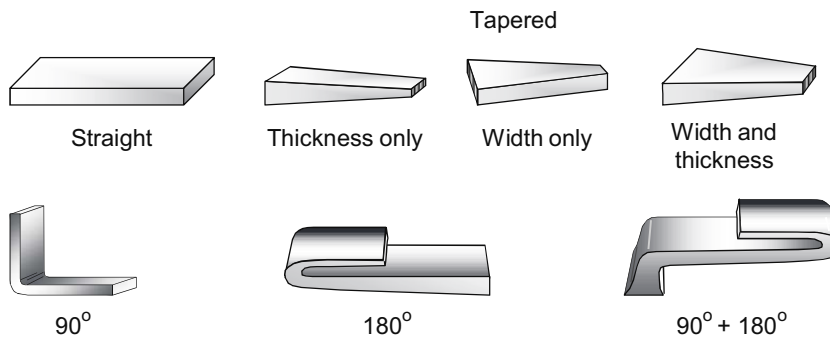

Beam sections

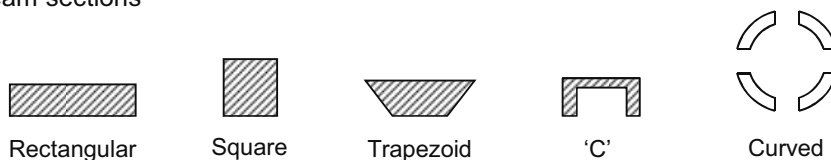

Figure 6.4 Cantilever beam deflecting members

Common lock orientations relative to a part are shown in Fig. 6.5. Note the interchangeability of the catch and the rectangular opening as retaining members on some of the beams. Again, as with locators, the lock feature is considered a separate feature from the surface or edge on which it is mounted.

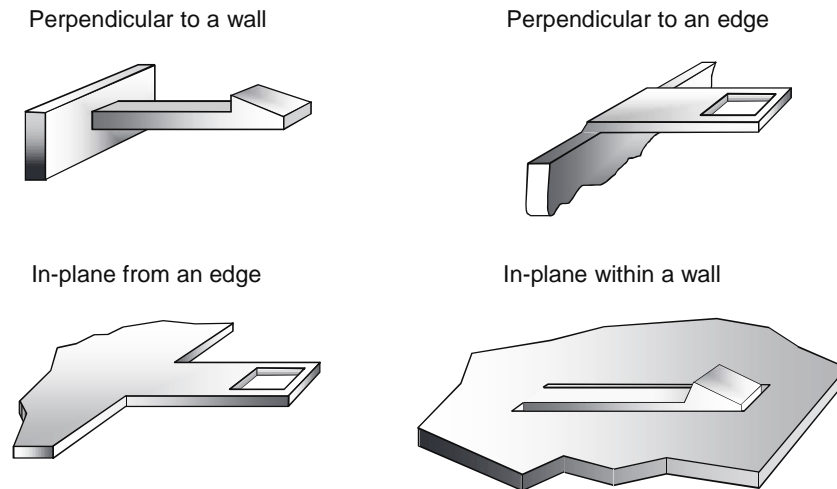

Figure 6.5 Common beam orientation to local part geometry

Lock features should be expected to constrain in the separation direction only, see Fig. 6.6.

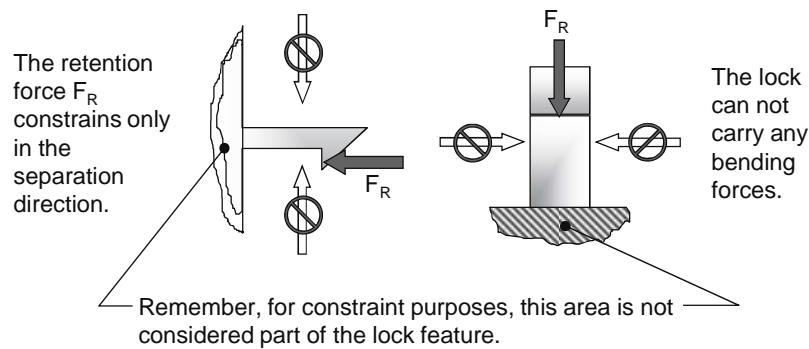

Figure 6.6 Locks should contribute to constraint only in the separation direction

In other words, all the lock should do is hold the mating-part in position.

One of the most common mistakes made in snap-fit design is to use the lock to react against forces other than just the force in the separation direction. This causes an under-constraint condition. Always ensure that locator features are present to carry these other forces.

It is also preferred that lock features carry no *significant* forces in the separation direction. This is because most locks tend to be relatively weak in that direction. It will be up to the developer to determine whether separation forces exist and are significant or not.

In reality, although we try to avoid it, an application may require a lock(s) to resist (sometimes significant) separation forces. As we will see, there are some cantilever

beam-based lock styles that can be quite strong in retention and are capable of resisting separation forces.

Figure 6.7 illustrates some very bad cantilever hook lock designs. All these mistakes have been found repeatedly on beam-based lock features in many different applications. Because they are mistakes associated with the deflecting, and not the retaining member, they can occur on any cantilever beam-based lock. Later in this section, we'll describe a common scenario illustrating how one of these bad designs can occur.



An extra long cantilever beam hook is too thin relative to its length for good retention strength. Strength can be improved by changing it to a loop. Retention strength can also be improved with the use of retainers. A common rule of thumb is the beam's length should be less than 10x its thickness.

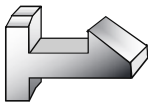

This beam is too short relative to its thickness and the insertion face is much too steep. These are often (improperly) used in short grip-length applications (there are better solutions). A common rule of thumb is the beam's minimum length should be at least 5x its thickness, longer if it is plated.

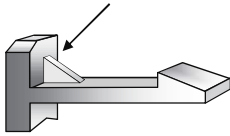

Lock performance can be adjusted by adding a rib. But putting it on the tension side of the beam will concentrate stress and strain where the rib meets the wall. If a rib must be used, it belongs on the beam's compression side.

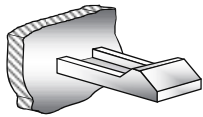

For the same reason as above, a beam with a 'C' cross-section should have the ribs on the beam's compression side.

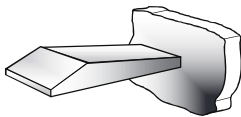

While tapering from the beam's base to its end can be a good idea, tapering in the opposite direction is not.

With this taper, all deflection stress and strain is concentrated at the beam's base and it will break.

Figure 6.7 Examples of bad cantilever lock designs

In the author's experience, the original mistakes in these designs are made due to a lack of snap-fit knowledge. But the poor design is often carried forward far too long in the development process. The reason for this is failure to admit or to recognize that a cantilever hook style lock was a bad choice in the first place. By this point, molds may have been made and it may seem that the design is locked in and that it is too late to change.

Of course, the best option is to avoid making a bad lock feature choice in the first place. Figure 6.36 (at the end of this chapter) shows how, in the author's experience, selecting the wrong lock feature style (usually this is a cantilever hook) is the single biggest cause of snap-fit problems.

If problems do occur, the first solution should be to redesign the lock area with minimal mold changes. Because the lock is part of a lock pair, changes to the lock area may also include changes to the locater area on the other part. This is another reason why resistance to making late changes can be so strong. An example of how minimal changes can sometimes be made to improve lock performance is given in the next section.

Chapter 14, “Diagnosing Snap-Fit Problems,” also lists possible lock feature changes to minimize redesign.

6.3.1 Hooks

One of the most important lessons to be learned is when not to use hooks.

Cantilever hook locks are by far the single most common snap-fit lock style. They are relatively easy to understand, analyze, design and manufacture as an integral attachment. Their popularity can lead to the perception that cantilever hooks represent snap-fit technology. (See Section 1.2 in Chapter 1 and Section 15.3 in Chapter 15 to read about the *battery cover syndrome*.) One bad experience with a cantilever hook can cause a developer or even an entire company to avoid using snap-fit technology at all.

Hooks have their place as an attachment option, but they should not necessarily be the default lock feature selection. The reader will learn about cantilever hook limitations and about methods to improve hook retention performance when needed.

Figure 6.8 identifies the major features of cantilever hooks.

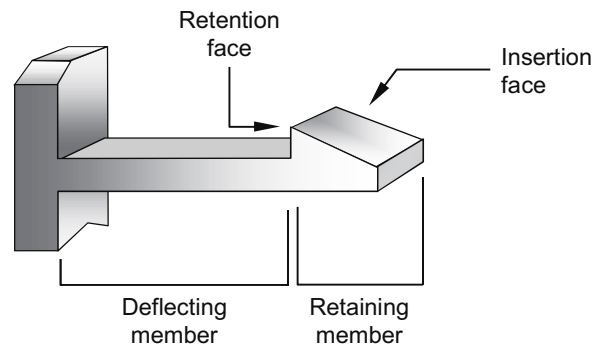

Figure 6.8 The basic hook

Figure 6.9 describes an all too common hook development scenario. The author has seen this particular poor hook design so many times and in so many different products that it deserves special attention. It has been found, broken, on very expensive copying machines, a high (?) quality home vacuum cleaner (our own), and multiple other low and high cost products.

Adding a rib shortens the beam's length.

While they do have their place in lock design, the presence of a supporting rib is often a good clue that the original design had issues which lead to a series of attempted fixes. Often the first fix tried is adding a rib to support the beam. Often, this does not work as expected. If a cantilever hook requires a rib, then a different lock style is probably indicated.

Several illustrations in this book show parts with ribs added to cantilever hooks with a low L/T ratio (short hooks). These hooks were not the proper lock choice for the original design.

This scenario begins with a common error: *I've seen snap-fits, therefore, I can design them.*

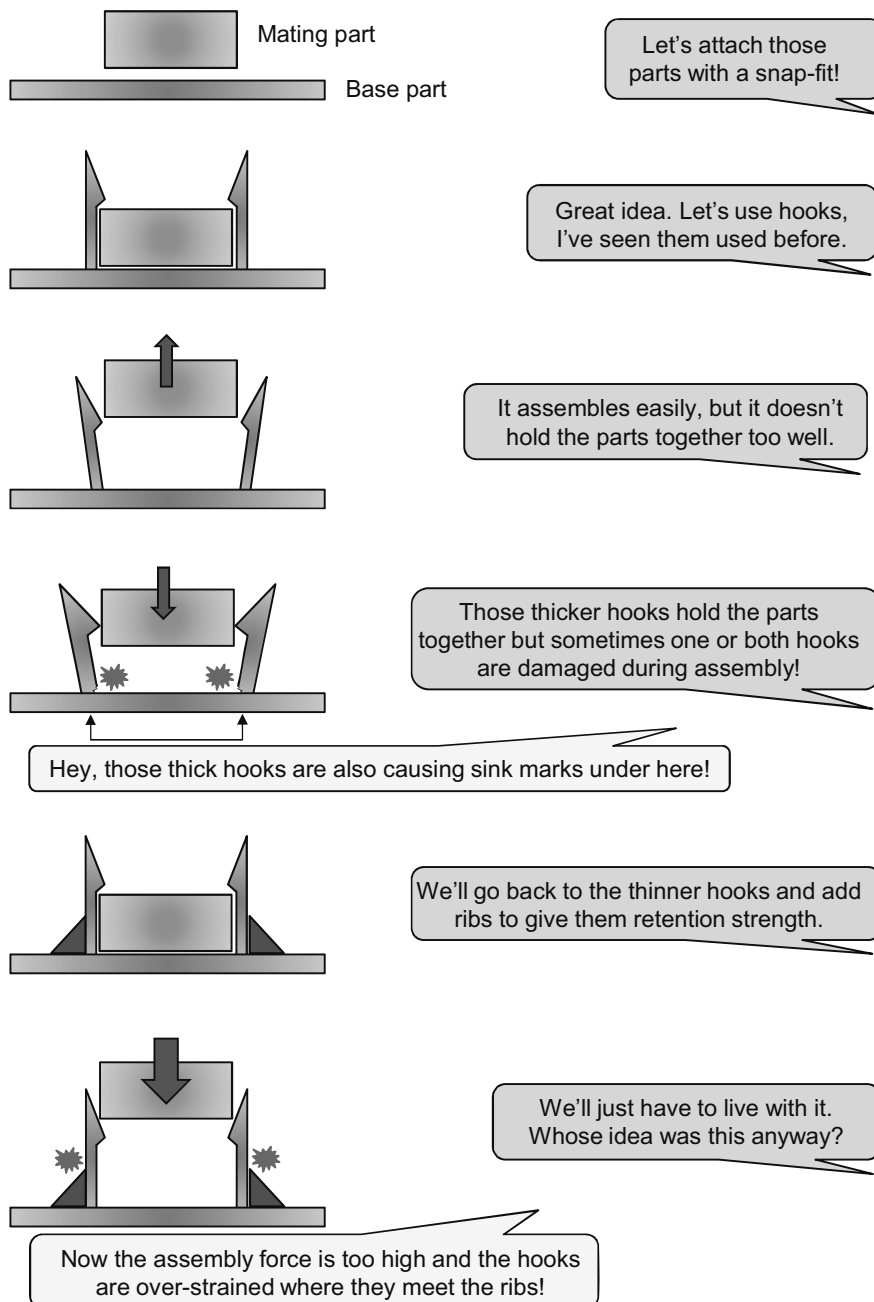

Figure 6.9 Common (bad) hook development scenario

■ 9.4 Manufacturing Enhancements

Manufacturing enhancements are design practices that support part and mold development as well as long-term manufacturing needs and part consistency. Many are documented in standard design and manufacturing practices for injection-molded parts and are already recognized as important factors in plastic part design. They fit neatly into the ALC as enhancements.

These enhancements make the part easier to manufacture and provide benefits in:

- Cost reduction
- Shape consistency
- Appearance
- Mold development
- Reliability
- Reduced internal stresses
- Process cycle time
- Performance consistency
- Fine-tuning for development
- Adjustment for variation and mold wear

This section is not a comprehensive guide to mold design and it will not make the reader an expert in the field. Because the part developer is most familiar with the application's requirements and is in the best position to ensure they are properly considered, a basic awareness of some processing concepts and practices is essential. The intention is to capture this aspect of snap-fit design as an enhancement and present a few of the more basic concepts that relate directly to snap-fits. The reader will learn enough to recognize design issues and then seek assistance from experts.

Remember that snap-fit features are subject to the same rules of good mold design as are the other features in an injection-molded part. For example, snap-fit features that protrude from a wall or surface should be designed according to the injection molding guidelines for protrusions. Be aware that the nature of some snap-fit features may require violating some guidelines. This is particularly true when features are tiny and/or close together. In these cases, discuss the requirements with the mold developer and the manufacturer.

Manufacturing enhancements fall into two groups. Those that improve part production are called *process-friendly* and are related to mold flow, mold and part cooling, and cycle times. Those that enable relatively easy dimensional changes to the mold for dimensional adjustments to parts are *fine-tuning* enhancements.

9.4.1 Process-Friendly Design

Required Enhancements:
Guides
Clearance
Feedback
Process-Friendly Design

Process-friendly design is simply following recommended and preferred plastic part design practices. Process-friendly parts are more robust to the molding process and are likely to be less expensive and more consistent in performance.

Part designs that violate recommended practices are likely to require special care during processing. For example, tiny features and very thin walls violate some of the general guidelines regarding section thickness. These features may not be as robust or process-friendly as larger features but they can be molded when processing accommodations are made and process variation is carefully controlled.

The information in this section was drawn from a number of publications. It represents *general design knowledge for a wide range of polymers* and can be found in multiple documents. Rather than cite numerous publications for each item presented, all the source publications are listed at the end of this chapter.

Process rules and guidelines can also change as materials and processing technology evolves and references can become outdated. The process-friendly guidelines given here are useful as a starting point but part developers must ensure their designs reflect current processing technology and best practices for their specific part material.

The single most important rule is to keep a design as simple as possible. Simple feature designs mean less costly molds and greater part consistency. Access for molding undercuts is always an issue in part design and snap-fits are no exception. Parts and features that can be produced without the added complexity and cost of slides and lifters (die-action) are always preferred.

Some general guidelines for process-friendly design are shown in Figs. 9.17 and 9.18.

In most of this book's illustrations, radii at all feature corners are not shown. However, the reader must know that a basic rule of plastic part design is to avoid sharp interior and exterior corners. This rule applies to snap-fit features where the feature meets the parent material as well as at all the angles and corners within the feature itself. Sharp internal corners create sites for stress concentrations. When at the base of a load-carrying constraint feature, sharp corners can cause feature failure.

Specify a radius for inside and outside corners. The idea is to maintain a constant wall thickness for smooth plastic flow through the mold; *the melt front does not like surprises*. Corners cause turbulence and are hard to fill. It is not enough to simply ask for fillets and radii in a general drawing note. Call out a fillet or radius dimension on the part drawing at every site where one is required.

Treat every protruding feature (hooks, pins, tabs, lugs, etc.) as a rib and follow the guidelines for rib dimensions and rib spacing. Specify a wall thickness and protrusion thickness so that voids or residual stresses at the base of the feature do not occur.

If a part shows sink marks on the opposite side of a wall from a feature, this indicates that voids or residual internal stresses exist at the feature's base. These will weaken the feature and may result in failure.

Always include a draft angle. This allows the part to be easily removed from the mold. Start with the basic feature size then add the angle to each side. There are many sources of draft angle information, including [6].

Note how the protrusion height (H) limitation relative to wall thickness shown in Fig. 9.18 is frequently violated by cantilever beam lock features and pin locators, for example. This is acceptable if processing accommodations are made and the material permits it.

Avoid thick sections and abrupt section changes for the same reasons sharp corners should be avoided. Another reason is the difficulty of cooling thick plastic sections. To properly cool a thick section results in significantly longer cycle times and higher cost. Where die faces come together in shear, a shut-off angle is necessary. For instance, this will occur when access is required for molding undercuts in hooks or lugs.

Use simple shapes and allow for die access and part removal.

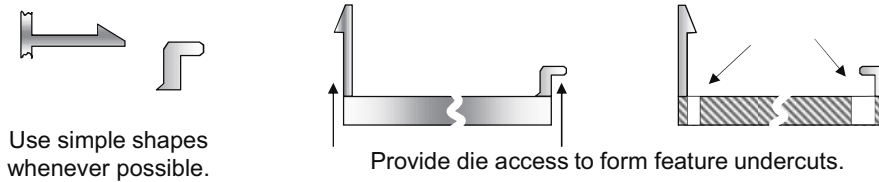

Specify radii at all internal and external corners.

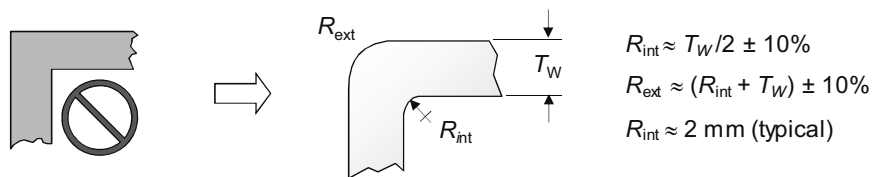

Note: A general note on the drawing may not ensure proper use of radii and bevels. Show specific radii and bevel dimensions at each required location.

Adjust protrusion thickness relative to the wall thickness and add a radius at the wall.

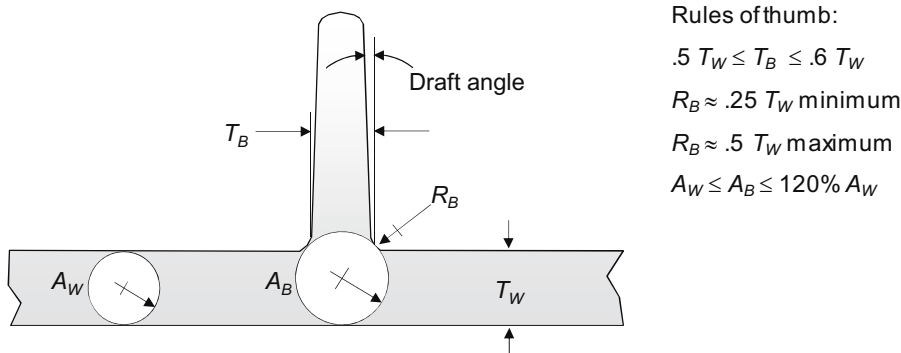

- Using part wall thickness (T_W) as the starting point, calculate the protrusion thickness at the base (T_B). The draft angle is then applied at the base.
- Add a radius (R_B) at the protrusion base.
- Verify the material area (A_B) at the protrusion base does not exceed about 120% of the normal wall area (A_W).

Figure 9.17 Common process-friendly design practices

Protrusion spacing

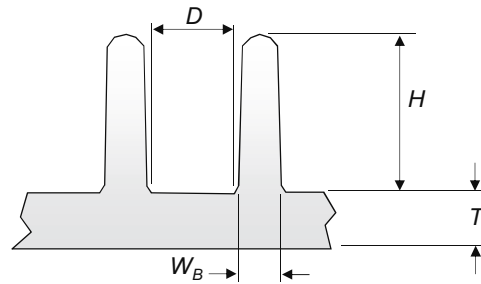

Rules of thumb:

$H \leq 5T$

$D > 15 \text{ mm (typical)}$

$D > 3H \text{ (minimum)}$

Draft angles

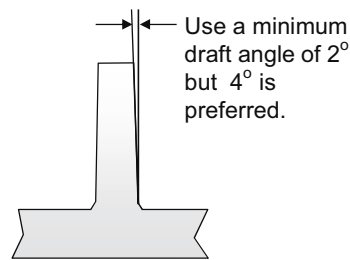

Taper all section changes

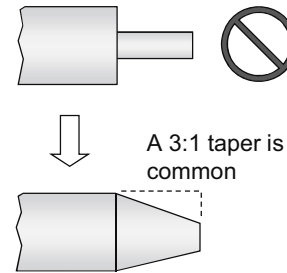

Avoid thick sections

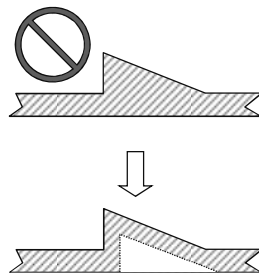

Core out thick sections, typical wall thickness is ~ 2-4 mm.

Shut-off angle

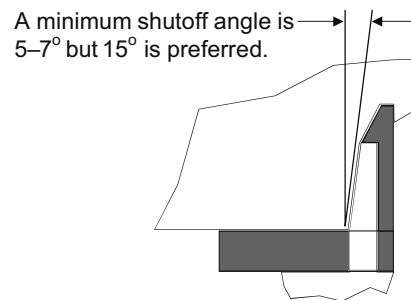

A shut-off angle reduces wear and prevents damage where the die faces would meet in shear.

Figure 9.18 Process-friendly designs, continued

Pay attention to gates; they are areas where the plastic melt enters the mold cavity and gate style and location can affect snap-fit feature performance. Gates were discussed with respect to loop style locks in Chapter 6, Section 6.3.2.3.

Mold designers are not likely to know a part's critical areas and will put gates at locations they believe are the best sites for mold fabrication and the molding process unless the part designer indicates otherwise.

Gates should be located:

- Away from flexible features and impact areas.
- So that knit lines will not occur at high stress areas, including living hinges.

- In the heaviest/thickest sections so that flow is to the thinner, smaller areas.
- So flow is across (not parallel to) living hinges.
- So flow is directed toward a vent.
- In nonvisible areas.
- So that flow distance to critical features is not excessive.

Gate location can also affect part warpage. Be sure snap-fit features do not move out of position due to excessive part warpage. If they do, guide enhancements may be needed to bring the locks back into proper position for engagement.

Some of these process-friendly guidelines exist to help the manufacturer optimize the production process. Optimization includes minimizing cycle time. Some of the guidelines can be violated at the cost of higher cycle time. Very close communication between all stakeholders is required to ensure the required process parameters for quality parts are understood and maintained throughout the production life of the product. Beware that when a part design increases the cycle time, there may be a temptation to speed that time up once the part is in production.

Most importantly:

- Communicate directly with the material and part suppliers and mold maker to ensure all design requirements are understood and met. Section 13.3.1 in Chapter 13 describes how failure to communicate about draft angle requirements resulted in lock feature problems.
- Refer to current published rules and guidelines for mold design for the specified part material.
- Consider all protrusion features as ribs and follow rules for rib design and spacing.
- Always specify radii and smooth transitions between sections of different thickness.
- Pay special attention when, of necessity, a design falls outside of process-friendly guidelines.

9.4.2 Fine-Tuning Enablers

Fine-tuning capability makes initial mold adjustments easier. Despite continuous advances in materials, processing and part and mold-flow analysis, the nature of plastic means the first parts to come out of a mold are likely to require some fine-tuning.

Fine-tuning capability also accommodates long-term part and production variables. Once production begins, mold wear, variations or changes in raw materials, design changes, and variation in other parts may also require mold adjustments to maintain attachment integrity.

In anticipation of the need for initial and long-term adjustments, the developer should plan for mold tuning at strategic locations. The purpose is to avoid large-scale mold changes that would be expensive and time-consuming.

The first step in adding fine-tuning enhancements is identifying where compliance is possible relative to critical alignment and positioning requirements and the associated

Be aware of the relationship between compliance and fine-tuning sites.

10

Applying the Snap-Fit Development Process

To provide some context for the elements and concepts discussed in Chapters 4 through 9, the Snap-Fit Development Process was introduced in Chapter 3.

This chapter explains in detail how those elements and concepts are used in the development process to create a snap-fit application, see Fig. 10.1.

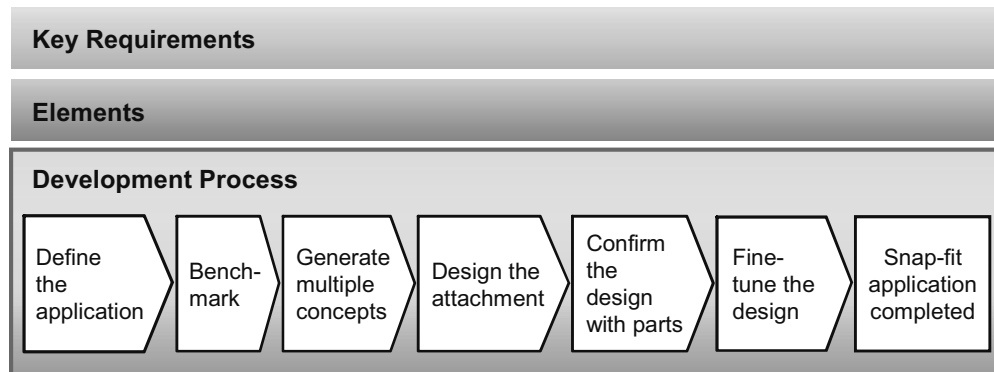

Figure 10.1 The snap-fit development process in the ALC

In Chapter 3, a preliminary *Step 0* was described in which the decision to use a snap-fit attachment was made. The discussion in this chapter assumes the choice to proceed with a snap-fit application has been made.

Recall from Chapter 3 how the development process begins with creating a good attachment *concept*. In the process, Step 3, - *Generate Multiple Concepts*, and Steps 1 and 2 that lead up to it, may appear to be a waste of time, but they are not because:

- Most of a product's cost is established during the concept development stage.
- Starting with a good concept will help ensure attachment reliability and quality.
- Issues that will require future correction are avoided and time-consuming development iterations are minimized.

The concept development stage may look difficult or time-consuming. Once the reader understands the process, it will become easy. It is primarily a thinking exercise with some product benchmarking. It does not involve detailed design - simple hand sketches of concepts and ideas are recommended.

Most snap-fit developers are not materials or processing experts. The snap-fit development process should include input from a polymers expert, preferably as early in the design process as possible. Input from processing experts is also recommended. If possible, also include the final part manufacturer(s) in the process.

Figure 10.2 repeats a figure from Section 3.5 showing where decisions about the spatial/descriptive and physical elements are made during the development process.

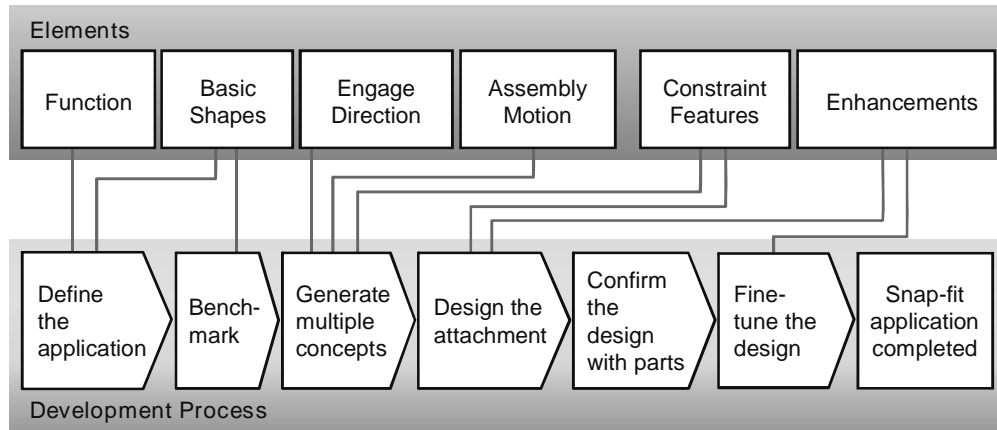

Figure 10.2 The relationship between elements and the development process

■ 10.1 Step 1: Define the Application

The application is first defined using the descriptive elements *function* and *basic shape*. Function, summarized in Table 10.1, describes the nature of the locking requirements for the attachment. The purpose is to explicitly define what the lock feature(s) must do in the application so there can be no misunderstanding when decisions about lock feature selection are made later in the process. Refer back to Chapter 4 for details.

Table 10.1 Define the Lock Feature’s Function in the Application

Action	Movable	Free movement or controlled movement
	or	
	Fixed	No movement once latched
Purpose	Temporary	Until final attachment is made
	or	
	Final	Snap-fit is the final attachment
Retention	Permanent	Not intended for release
	or	
	Nonpermanent	May be released
Release	Releasing	Releases with applied force on the mating-part
	or	
	Nonreleasing	Lock is manually deflected for release

Basic shapes are generic descriptions of the part's geometry, see Table 10.2. The common/rare designation is based on the author's observations. In any specific product field, the frequency of these combinations may be different and an appropriate frequency table can be developed.

Basic shape frequency is related to a business strategy of establishing a library of common/preferred basic shape combinations, which is discussed in Chapter 15.

Table 10.2 Likely Basic Shape Combinations

	Solid	Panel	Enclosure	Surface	Opening	Cavity
Mating-part	Common	Common	Common	Rare	Rare	Low
Base-part	Common	Rare	Rare	Common	Common	Common

Defining the application using these attachment level terms will help when design rules are applied later in the process. Their immediate value, however, is in helping the developer structure a search for ideas as they conduct technical benchmarking in the next step.

In addition to the general *key requirements* for snap-fits, each application will have specific performance requirements and in-service conditions which must be defined. Some of these need not be known at this stage of the process, but will be needed eventually. The sooner this information is collected, the better. Application-specific requirements and conditions include:

- Material properties
- Manufacturing limitations and capabilities
- Load-carrying and retention requirements
- Thermal history for the application
- Alignment and appearance requirements
- Environmental conditions such as chemical and ultra-violet exposure
- Product service conditions and requirements

At this time, the developer should begin rough hand-drawn sketches of the application in terms of its basic shapes. These *concept sketches* are used to capture ideas and alternatives throughout the concept development step. The developer should also begin thinking about how a crude model of the application can be constructed.

This is also the time to identify certain *red-flag* issues. These are not issues that would necessarily prevent use of a snap-fit, but they must be given extra attention because of their potential for special difficulties in attachment development.

Red-flag issues include:

- *Short grip length:* A lock feature having beam length less than $\sim 5x$ its thickness. Cantilever hook locks typically do not work well in this situation. Use a lock style with higher decoupling capability.
- *Brittle or rigid material:* Will be much more sensitive to stress concentrations, small radii, assembly strain, over-deflection, and short grip lengths. This includes plated plastic parts.

13.6.1 Lock Assembly Force

We calculate maximum assembly force to ensure a lock can be assembled without violating ergonomic rules for forces applied by fingers, thumbs, or hands. Even automatic or robotic operations require consideration of assembly force. Issues could include the size/capacity of the assembly machine or possible part damage if assembly forces are too high.

For assembly, the insertion face is a ramp on which the mating feature slides and Eq. 13.25 is the basic equation for assembly force.

$$F_{\text{assembly}} = F_p \frac{\mu + \text{Tan}\alpha_{\text{design}}}{1 - (\mu \text{Tan}\alpha_{\text{design}})} \quad (13.25)$$

An important adjustment to this equation is required because the insertion face *design* angle is commonly *and improperly* used in assembly force calculations.

13.6.1.1 Adjusting for the Insertion Face Effective Angle

Effective insertion face angle is one of the required calculation adjustments.

The author is not aware of any published or online calculations that consider the effect of beam deflection on the *insertion* and *retention* face angles. When sample calculations are shown, they typically use angle values for the lock in its free, (or *as-designed*) state as shown in Fig. 13.22 and Eq. 13.25. In reality, these angles can change significantly as the beam on which they are mounted deflects and those changes will affect the force calculations. The design angles must be adjusted to reflect the insertion and retention face *effective angles*. If these changes are ignored, then the calculated assembly force will be lower and the calculated separation force will be higher than the actual values.

Insertion and retention face angles were also discussed in Section 9.1.6 and Fig. 9.10, and in Section 12.2.

The adjustment described in Fig. 13.23 assumes no retaining member rotation and no beam curvature during deflection. When a beam is long relative to its thickness or when a beam is tapered, rotation and curvature may be significant. However, this simplified calculation will bring the calculated assembly force much closer to reality than ignoring the angle changes altogether. A more complex calculation that takes beam curvature and end rotation is possible but normally not necessary.

Assembly behavior - The catch's insertion face angle will change during assembly deflection:

This figure illustrates catch behavior when it is part of a cantilever hook style lock.

Catch behavior will be different on a trap style lock or when the catch is the locator feature in a lock pair.

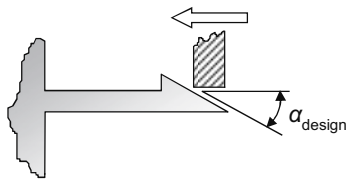

The design angle applies only when the mating feature first engages the catch.

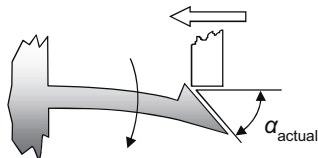

As the mating feature moves up the insertion face, the beam deflects and α increases. Beam curvature and end rotation also contribute to the increase in α .

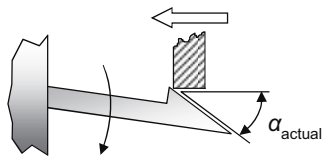

To simplify the calculation, we'll ignore beam curvature and end rotation. However, it is possible to include those effects if desired.

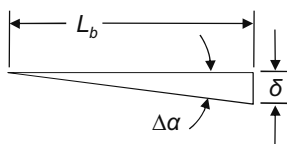
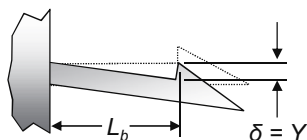

The change in angle becomes a simple trigonometric calculation using beam deflection and beam length.

The net effect of increasing beam deflection force and increasing insertion face angle is a geometrically increasing insertion force signature that results in higher maximum assembly force than necessary.

Figure 13.23 Catch insertion face behavior and the effective angle

To calculate the maximum assembly force, we must know the effective angle at that point. First calculate the change in insertion face angle at maximum deflection using Eq. 13.26. Use the maximum deflection from the deflecting member calculations, or for a more conservative result, use the design retention face height (Y) in the calculation.

$$\Delta\alpha = \text{Tan}^{-1}\left(\frac{\delta}{L_b}\right) \quad (13.26)$$

For simplicity in the discussion, we will always show L_b in the equations and use it in the calculations. There may be times when using L_e in these calculations would be appropriate for the additional precision it could provide in the profile calculations. See the discussion about beam length in Section 13.2.2 and Fig. 13.2.

Add the change in angle to the original design angle to find the effective insertion face angle, Eq. 13.27.

$$\alpha_{\text{effective}} = \alpha_{\text{design}} + \Delta\alpha \quad (13.27)$$

Because both beam deflection force and insertion face angle increase as the lock deflects for assembly, their effects are additive and maximum assembly force always occurs at maximum deflection. In the calculations, we'll use:

- Maximum deflection force ($F_{p\text{-final}}$) calculated for the beam deflecting member.
- Effective insertion face angle ($\alpha_{\text{effective}}$) calculated using Eq. 13.27.
- A friction coefficient (μ) based on test data, tabulated values or our own experience.

Reread the discussion about friction coefficient uncertainty in Section 11.5.

Find a friction coefficient in Chapter 11 in Table 11.3 or from supplier data. However, friction coefficient data for plastics can be highly variable and truly accurate values are difficult to find. If friction coefficient data is not available, make a judgment from the available data depending on the lubricity of the material(s), surface roughness, and a bias toward a high or low estimate of force depending on the application.

Note the friction coefficient in Eq. 13.28 is not labeled as *static* or *dynamic*. Because the surfaces are sliding across each other during assembly, we should be using a dynamic friction coefficient value; if one is available, use it.

In the author's opinion, given the nature of friction data and the other assumptions and variables associated with these calculations, distinguishing between static and dynamic friction coefficients is generally unnecessary.

Maximum assembly force is found using Eq. 13.28, which is identical to Eq. 13.25 but uses the *effective* insertion face angle rather than the design angle.

$$F_{\text{assembly-max}} = F_p \frac{\mu + \text{Tan}\alpha_{\text{effective}}}{1 - (\mu\text{Tan}\alpha_{\text{effective}})} \quad (13.28)$$

This is the maximum assembly force for one lock feature. When multiple locks engage simultaneously, multiply the result by the number of locks.

13.6.1.2 Example Assembly Force Calculations

Figure 13.32 in Section 13.9 shows how to construct a spreadsheet to perform these calculations.



Example assembly force calculation

Given:

Insertion face angle (α_{design}) = 25° From Chapter 12, Rules-of-Thumb.

From Fig. 13.8, application data:

Friction coefficient, (μ) = 0.3

Beam length, (L_b) = 15.0 mm

Results from straight beam example calculation:

Deflection, $\delta_{\text{actual}} = 1.48$ mm

Deflection force, $F_{p\text{-actual}} = 4.8$ N

Using Eq. 13.26:

$$\Delta\alpha = \tan^{-1}\left(\frac{\delta}{L_b}\right) = \tan^{-1}\left(\frac{1.48}{15.0}\right) = \tan^{-1}(0.0987) = 5.6^\circ$$

Using Eq. 13.27:

$$\alpha_{\text{effective}} = \alpha_{\text{design}} + \Delta\alpha = 25^\circ + 5.6^\circ = 30.6^\circ \approx 31^\circ$$

So $\alpha_{\text{effective}} = 31^\circ$

For use in Eq. 13.28:

$$\tan\alpha_{\text{effective}} = \tan(31^\circ) = 0.6009$$

Using Eq. 13.28:

$$F_{\text{assembly-max}} = F_p \frac{\mu + \tan\alpha_{\text{effective}}}{1 - (\mu \tan\alpha_{\text{effective}})} = 4.8 \times \frac{0.3 + 0.5922}{1 - (0.3 \times 0.5922)} = 5.14 \text{ N}$$

So $F_{\text{assembly-max}} = 5.14$ N per lock

13.6.1.3 Modifying the Insertion Face Profile

The above example shows how to use the change in insertion face angle at maximum deflection to find a more accurate and higher value for maximum assembly force. But the insertion face is flat and will have an assembly force signature with an increasing rate of change. See Fig. 13.24 and the discussion of assembly feedback in, Section 9.1.6.

We can also use the concept of effective angle to design a profile for the insertion face to offset the deflection effect and reduce assembly force without changing beam deflection or affecting the separation force.

Section 9.1.6, discussed the assembly force signature and its effect on assembly feedback. With our knowledge about the effective angle we can use it, if we wish, to modify the insertion face profile to improve the insertion force-deflection signature.

■ 15.5 The Snap-Fit Capability Plan

The goal is world-class capability in snap-fit attachments.

One component of *organizational* capability is *individual* capability, and it is possible to have the latter without the former. The true competitive advantage lies in having both.

The balance of this chapter describes a detailed plan, summarized in Fig. 15.5 that goes beyond simply training individuals about snap-fits. It should be adapted to reflect an organization’s particular needs, culture, resources, and business environment. A few *must do* items are identified, but the reader is generally free to choose how to adapt the plan to their organization.

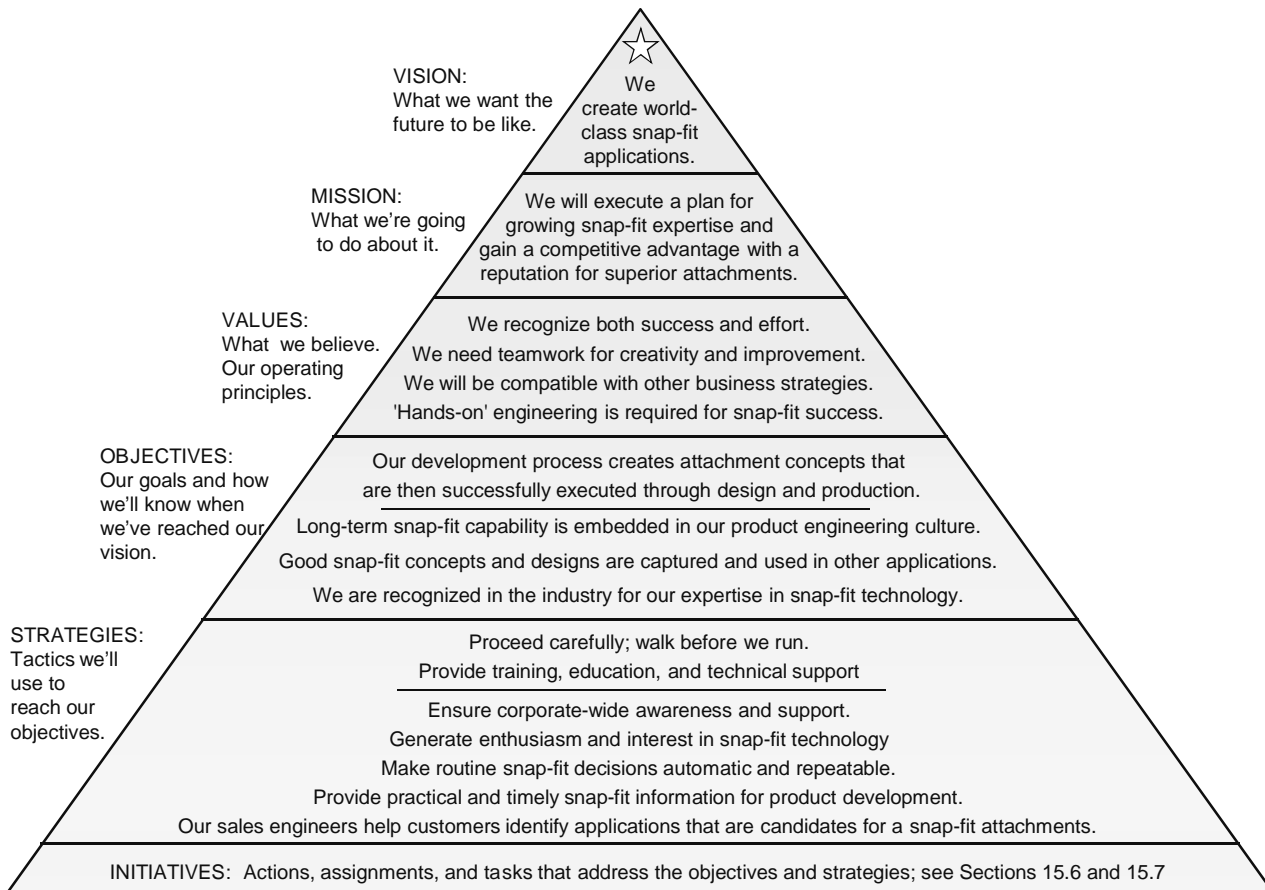

Table 15.1 shows a simplified version of this plan.

Figure 15.5 Snap-fit capability plan for an organization

15.5.1 Vision, Mission, and Values

The *vision* and *mission* statements should be adapted to reflect the organization's own needs and culture.

Some of the statements in the *values* area reflect generally recognized good personnel practices, *teamwork* and *recognition* for example. Others can be developed by the organization.

The value *hands-on engineering is essential to understanding and creativity* should be included in every organization's plan for snap-fit competence. Because of the creative and visual aspects of snap-fit attachments and the spatial-reasoning required for good concept development, it is essential that product developers have access to real parts and models.

Get your hands on real parts!

15.5.2 Objectives

Objectives are also *goals*. We are now moving from intangibles to more concrete elements of the plan. All the objectives are observable outcomes; they can be seen and measured. When we see them, we know we are doing the right things to reach our corporate vision. By measuring them, we can ensure steady progress toward that vision. All strategies must be realistic and targeted to ensure meeting these objectives.

One objective reflects personal or individual snap-fit expertise and is essential if you simply wish to ensure your developers can create reliable snap-fit applications.

- Our development process consistently creates sound attachment concepts which are then successfully executed through design and production.

Some companies may choose to address this objective only and go no farther. However, it does not resolve any *long-term* capability issues.

Three more objectives are recommended if your organization is to become *snap-fit capable*. They will move the organization's engineering culture toward a higher level of snap-fit expertise and ensure a long-term competitive advantage.

- Long-term snap-fit capability is embedded in our product engineering culture.
- Good snap-fit concepts and designs are captured and used in other applications.
- We are recognized in the industry for our expertise in snap-fit technology.

15.5.3 Strategies

Strategies are *tactics* used to reach the objectives. Strategies are where an organization can identify unique strengths or opportunities to gain an advantage over the competition. Consider using those listed here and others developed within the organization. Each strategy must be supported by specific initiatives.

Two near-term strategies will get individual product developers started on snap-fits. Both are highly recommended. As with the essential objectives described above, an

organization may choose to address these strategies and forgo the larger corporate effort.

- *Proceed carefully: walk before we run*

It is important to avoid bad experiences with any new technology so it is not rejected before it has a chance to take hold. Manage the transition to snap-fits carefully and start your designers on low risk applications. With experience, they will be comfortable taking on applications that are more difficult. A careful, managed approach will also allow other parts of the organization with a stake in snap-fits to get up to speed.

- *Provide training, education and technical resources*

Training and education will help designers move quickly up the learning curve, avoiding many common mistakes made by beginners. Of course, training and education should be on-going and although it starts out as a near-term strategy, it should remain in place for new designers. Development of in-house advanced training specific to your products is also possible. Access to technical resources, including materials and manufacturing subject matter experts, literature, and software is also important. Refer to the appendix for more information.

Longer-term strategies build on the near-term strategies and are intended to embed a high level of snap-fit capability into the organization's culture.

- *Ensure corporate-wide awareness and support*

Snap-fit decisions will affect other parts of the organization. Make sure all stakeholders are involved.

- *Generate enthusiasm and interest in snap-fit technology* This is a common human resources and motivation based strategy.

- *Make routine snap-fit decisions automatic and repeatable*

Most snap-fit decisions will be of the routine variety. Prioritize and capture them first in the preferred concepts library. A logical place to start is with the basic shape combinations that appear most frequently in your products. Attachment concepts for these applications can be standardized to reduce the possibility of problems and save time and effort in future product development work.

Once less time is spent *reinventing* these routine attachments, the less common applications can be addressed.

- *Provide practical and timely snap-fit information for product development*

This strategy has aspects of the near-term "Provide Technical Support" strategy, but it goes far beyond passive or reactive support from other experts.

- *Sales engineers can identify applications that are candidates for snap-fit attachments*

Helping customers reduce cost is a great way to gain business and good results will build credibility.

Once the strategies are established, initiatives to support those strategies can be identified. Each initiative must support at least one strategy and one objective. The following sections discuss the initiatives in detail.

The capability plan shown in Fig. 15.5 and described in the following sections is intentionally large and detailed in order to capture as many important topics as possible. Table 15.1 shows the most important parts of the plan in a very simplified form and is

probably a more realistic starting point for most organizations. The initiatives are selected for their importance and ease of implementation.

Table 15.1 Simplified Capability Plan

Values	<ul style="list-style-type: none"> ▪ Hands-on engineering with real parts and models is required for snap-fit success.
Objectives	<ul style="list-style-type: none"> ▪ Long-term snap-fit capability is embedded in our product development culture. ▪ Good snap-fit concepts and designs are captured and used as a starting point for future applications.
Strategies	<ul style="list-style-type: none"> ▪ Make routine snap-fit decisions automatic and repeatable.
	Start with the first four initiatives, shown in bold.
Initiatives	<ul style="list-style-type: none"> ▪ Make display posters of the harmful beliefs. ▪ Make display posters of the snap-fit technical domain, the ALC or your own. ▪ Make education, training, and technical resources available. ▪ Create and maintain a library of preferred snap-fit concepts. ▪ Make snap-fit technology visible in the organization ▪ Provide parts, physical models, and other products for study and benchmarking. ▪ Include specific snap-fit requirements in your bidding and purchasing process.

■ 15.6 Initiatives for Getting Started

Initiatives are practical *working level* activities expressed as actions, assignments, and tasks. The results or outcomes of each initiative should be observable and measurable.

A total of 15 initiatives are proposed; think of them as a wish list. All are important, but reality may dictate that some be excluded. Some are more critical to success than others and the author's recommendations will be shown in Table 15.4. A manager may choose to implement some of them as stated, ignore some, modify others, and perhaps create new ones.

The first seven initiatives focus on developing and supporting individual expertise and are also the starting point on a path to becoming a snap-fit capable organization. They are:

- *Provide education and training.*
- *Provide technical resources.*
- *Identify low-impact applications as a starting point.*

Index

A

accelerated aging 246
action 42, 204
additives 246
adjustable inserts 194, 196
adjustments
– for effective angle 312, 319
– for mating feature/part deflection 283
– for wall deflection 279
– to calculations 269
ALC 9
alignment requirements 185
annular locks 80, 107
application considerations 33
applications
– with fixed strain 239
– with variable strain 240
aspect ratio 280
assembly
– feedback 170, 172
– feel 87
– force 77, 312
– strength 24
assembly motion 22, 41, 52, 54, 67–68, 103, 160, 212–213, 215
– pivot 156
– slide 156
– tip 156
– twist 156
assists 176, 179, 198
assumptions for calculations 270
attachment level 7, 17, 337
– construct 9–10
– problem diagnosis 340
– symptoms 340
attachment strength 52, 67
attention to detail 11
automatic assembly 212

B

back-up features 187
back-up locks 182
base part 20, 45, 52, 64, 134, 157
basic shape 45–46, 68, 204–205, 207, 212, 215, 371
basic shape combinations 48, 54, 205
battery cover syndrome 84, 353
beam(s)
– based locks 251

– bending equations 276
– distortion 122
– effective length 275
– flexible length 276
– length 255, 275
– locks – other 104
– tapered in thickness 299
– tapered in width 304
– thickness 253
– width 257
benchmarking 159, 206, 215, 227, 251, 365
– checklist 207–208
best concept worksheet 221
bezel 127, 130
bidding and purchasing process 366
book contents 13–14
bosses 188, 224
brittle or rigid material 205
buckle application 181
business advantages 349
business case 32, 198

C

calculation adjustments 269
calculation assumptions 270
calculations for catches 311
calculation spreadsheets 330
cantilever beam
– analysis 81
– -based locks 269
– deflection 80
– lock configurations 81
– locks 81
cantilever hook 252
– assembly 86
– limitations 111
– locks 84
– separation 88
cantilever hooks 86, 170, 354
– and prongs 92
capabilities 29
captive washer 224
Cartesian coordinate system 19
catch 88
catch calculations 311
catch locator 60, 259
– feature 269
cavity 46
checklists 227

chemical effects 246
 chrome plated plastic 123
 clamp load 20, 134, 157, 185, 225, 349
 clearance 161, 163, 198
 clearance holes 188
 clips 226
 close tolerances 136, 141, 185
 CLTE 140–141, 247
 coefficient of friction 244
 coefficient of linear thermal expansion 140, 247
 coincident lines-of-action 140
 collinear lines-of-action 72
 common basic shapes 370
 common feature level problems 341
 common mistakes 339
 communication 10, 37
 compatibility 21
 competitive advantage 349
 complex interface 350
 complexity 37, 352
 compliance 69, 71, 143, 182, 184–185, 194, 199
 compliance enhancements 103, 156
 concept 30
 – development 30–31, 54, 203
 – library 207
 – sketches 205
 – stage 156
 cone locators 59
 confirm design 227
 considerations
 – application 35
 – information and data 35
 – material 35
 – organizational 35
 constraint 9, 19, 65, 73, 78, 108, 133
 – and locks 108
 – efficiency 72
 – feature design 75
 – features 55, 77
 – pairs 20, 156, 185, 215–217
 – rules 156
 – vectors 134, 141, 147
 – worksheet 134, 145, 217
 corner radii 190
 corporate
 – initiatives 363
 – memory 168
 – objectives 361, 363
 – strategies 361, 363
 – values 363
 cost distribution 38
 couple-rotation 70
 creativity 11, 41, 210
 creep 246
 critical
 – alignment 149, 195
 – dimensions 195

 – positioning 195
 – requirements 350
 cross-bar 262
 crush ribs 186–187
 cultural change 353
 customer complaints 337
 cutout locators 62

D

DAM 247
 darts 143, 186
 datum points 69, 72, 156
 decouple 77
 decoupling 52, 109, 117, 130
 – level 0 119
 – level 1 120
 – level 2 121
 – level 3 124
 – level 4 125, 137
 define the application 204
 deflecting member 78, 80–81, 251, 272
 deflection graphs 292
 deflection magnification factor 279
 deflection mechanism 107
 degrees-of-motion (DOM) 66, 108, 217
 demand 37, 352
 demand-complexity matrix 36, 351, 355
 descriptive elements 41, 54
 design 29
 – capability 37
 – for assembly 16, 43, 231
 – for manufacturing 16
 – point 239, 277
 – strain 277
 – window 117
 detailed design 30
 developer 351
 development 29
 – process 9, 29–30, 231
 DFA 16, 231
 DFM 16
 diagnose 169
 diagnosis 168, 337
 die-action 114, 254
 difficult assembly 337
 dimensional robustness 69, 139
 dimensional variation 184
 disassembly motion 22
 DOM 42, 66, 133, 217
 DOM removed 73
 door handle application 21
 door handle assembly 128
 draft angle 190, 254, 285, 297
 dry as molded 247
 dynamic strain 277

E

ease of assembly 69, 74
 edge locators 61
 education and training 364
 effective angle adjustment 312, 319
 efficiency 72
 efficient constraint 157
 efficient design 182
 elasticity 187
 elastic limit 237
 elements 9, 41, 203
 enclosure 45
 engage direction 41, 50, 211–212
 engineering executives 17, 349
 enhancement(s) 9, 24, 71, 159, 197, 220
 – features 91, 143
 – for activation 176
 – for activation and usage 198
 – for assembly 160, 198
 – for manufacturing 189, 199
 – for performance 182
 – for performance and strength 199
 – required 340
 ergonomic
 – design 214
 – factors 174
 – limits 226

F

fatigue endurance 246
 FEA 329
 feature analysis 222
 feature calculations 269
 feature damage 340, 342
 feature design 222
 feature level 7
 – problem diagnosis 341
 – problems 330
 – solution tables 343
 – technology 269
 feedback 161, 198
 fillets 98
 final attachment 43
 final evaluation worksheet 227
 fine tolerances 136
 fine-tuning 68–69, 193, 196, 199, 230
 fine-tuning enhancements 189, 230
 fine-tuning sites 149
 finite element analysis 329
 fish-hooking 103
 fixed applications 133
 fixed snap-fits 42
 force-deflection signature 174, 180, 316
 friction coefficient 314
 function 41, 45, 204

G

gates 192
 generic assembly motions 53, 67, 231
 generic basic shapes 231
 generic descriptions 52, 54
 grip length 115
 guards 182, 199
 guidance 161
 guide features 74
 guides 161, 198

H

hands-on
 – activities 31
 – engineering 361
 harmful beliefs 3, 353
 hidden locks 182
 high assembly force 341
 high demand applications 110
 high feature strain 342
 high separation force 342
 high speed tightening 224
 hole locators 62
 hook assembly signature 87
 hook style locks 80, 84

I

impact 37, 206, 352, 356, 365
 impact modified nylon 247
 improper constraint 139, 338
 incompatibility 21
 inefficient attachments 140
 inefficient constraint 157
 information 37
 – and data considerations 34
 insertion face 259
 – angle 259, 312
 – profile 87–88, 174, 315
 interface efficiency 156, 218
 interface options 41
 intermediate applications 368
 internal stress 253
 isolating materials 187

J

J-nuts 224

K

key requirements 9, 19
 knit lines 93, 96
 knowledge base 231
 knowledge transfer 41

L

land locators 61, 68
 level 4 decoupling 109
 line-of-action 64, 69, 141
 line-to-line fit 157, 185
 living hinges 56, 63
 local yield 185
 locator(s) 9, 20, 55, 72, 156
 – features 56, 156
 – pairs 55–56, 63, 73, 108, 142, 215
 – strength calculations 269
 – usage 63
 lock 9, 20, 77, 156
 – alternatives 223
 – analysis 251
 – as buckles 88
 – damage 342
 – deflection 78
 – efficiency 77, 101, 117
 – feature calculations 269
 – features 77, 156
 – feature selection 338
 – feature strength 339
 – pair examples 109
 – pairs 57, 108, 215
 – release 78
 – separation 78
 – strength 117
 – styles 80
 – usage 108
 long-term failure 337
 loop 262
 – assembly 94
 – locks 80, 93
 – separation 95
 loose fasteners 6, 223, 349
 loose tolerances 136
 low-clearance 109, 131
 low-deflection locks 58
 low-deflection lugs 103
 low-demand applications 368
 low-impact applications 364
 low retention strength 342
 lug locators 58
 lugs used as locks 103

M

machine thread screws 223
 making snap-fit technology visible 370
 managing expectations 352
 managing over-constraint 157
 manual-release 44
 manufacturing capability 37
 marking plastic parts 177
 material(s)
 – considerations 34

– properties 233
 – property data 233
 – with a definite yield point 240
 – without a definite yield point 241
 mating feature/part deflection adjustment 283
 mating part 20, 45, 50, 52, 64, 134, 157
 maximizing DOM removed 68
 maximum allowable strain 277
 maximum permissible strain 242
 mechanical advantage 73, 139
 metal inserts 224
 metal-safe design 194
 minimum material condition 195
 modulus 273
 moisture content 247
 mold design 189
 molding undercuts 191
 mold shrinkage 248
 moveable applications 133
 moveable attachments 42
 multiple concepts 31, 203, 210
 multiple constraint pairs 149

N

natural locators 55, 60, 196
 negative taper 297
 neutral axis 260
 nonreleasing loop 125
 nonreleasing trap 103, 125
 notch sensitivity 246
 novices 15

O

opening 46
 operator-friendly 214
 opposing constraint features 141–142
 opposing constraint pairs 143, 156
 organizational
 – capability 351, 360, 369
 – considerations 35
 – development strategies 349
 other lock styles 265–266
 over-constraint 136, 139, 156, 185, 248
 over-deflection 182
 over-design 353

P

panel 45
 panel application 138, 219
 panel-opening application 168
 panel-opening basic shapes 372
 parallel strength vectors 156
 part
 – buckling 140
 – distortion 337

- loosening 337
- release 337
- perfect constraint 134-135, 157
- performance enhancements 52
- permanent attachments 43
- permanent locks 52
- personal capability 351
- physical elements 55, 77
- physical models 365
- pilot holes 188, 224
- pilots 161, 164, 198
- pin locators 56
- pins 74
- pivot 52, 212
- planar locks 80, 105, 265
- plastic creep 185
- plastic tie-straps 103
- polymer experts 354
- position-critical 69
- positioning 69
- preferred concept 31
- preferred concepts initiative 372
- preferred concepts library 370
- preferred engage direction 51
- preferred interfaces display 375
- preferred materials 237
- preferred practices 48
- problem diagnosis 227
 - attachment level 340
 - feature level 341
- problem frequency 338
- problem root causes 339
- problem symptoms 337
- process-friendly 190, 199, 253
- product
 - developers 16
 - problem frequency 113
 - proposals 366
 - tampering 43
- prong locator 92
- prong locators 57
- prongs 92
- proof-of-concept 226
- proper constraint 135-136, 157
- proportional limit 237
- proposal checklist 209
- protrusion-based locators 56
- protrusions 56
- purpose 43, 204
- push 52, 156, 212
- push-in fasteners 223, 225

Q

Q-factor 279

R

- radii 93, 98
- rapid-prototyping 215
- rate dependent 246
- rectangular sections 273
- red-flag issues 205
- redundant constraint 157
 - features 140
 - pairs 156
- reflector application 25, 168, 173, 297
- regrind 247
- releasable attachment 44
- release 44, 204
- remove multiple DOM 156
- replacing threaded fasteners 349
- required capabilities 10
- required enhancements 198
- residual internal stresses 190
- resin suppliers 354
- resources 37
- restricted motion 42
- retainer enhancement 125
- retainers 91, 182-183, 199, 222
- retaining member 78, 88, 251, 259
- retention 43, 78, 204
- retention face 260
 - angle 88, 319
 - depth 260
 - profile 90, 323
- retention feature 256
- retention feature length 255, 276
- retention strength 269
- robustness 24, 69, 184
- rotational constraint 73, 148
- rotational DOM 148
- routine snap-fit decisions 362
- rules-of-thumb 251, 334

S

- sample parts 14
- screw 223-224
- secant modulus 237, 242, 273
- section properties 273
- self-releasing 44
- separation 78, 260
 - direction 51, 211
 - force 269, 319
 - strength 24, 52, 77
- service difficulty 337
- sheet metal screws 223
- short grip length 109, 123, 131, 205
- short grip-length application 91, 137, 170
- short-term failure 337
- shut-off angle 191
- side-action locks 91, 121
- sink marks 190, 253

slide 52, 212
 slot locators 62
 snap-fit 4
 – capability plan 360, 362
 – capable 351, 361
 – capable organization 349
 – development process 29, 31, 203
 – minimum requirements 366
 – problems 337
 – technology 349
 soft or flexible material 206
 solid 45
 spatial elements 41, 54
 spatial reasoning 11, 41, 52, 231
 speaker assembly 134
 spin 212
 spiral flow curves 255
 spring clips 223
 spring steel clips 188
 squeaks or rattles 337
 stability 73, 138
 stakeholders 221
 standard attachment concepts 123
 standard attachments 370
 static strain 277
 stationary catches 325
 strength 24
 strength estimates 239
 stress concentration 254
 stress concentration adjustment 277
 stress relaxation 247
 stress-strain curve 234–235, 238–239
 supporting ribs 114
 surface 46
 surface-based locators 56, 60
 surface locators 60
 surfaces 56
 symptoms 337

T

tab locators 58
 tamper resistance 43, 103, 266
 tamper resistant applications 111
 tapered beam calculations 296
 tapered features 186
 taper error 297
 tapering 256
 target strain 277
 technical memory 168
 technical resources 364
 technical understanding 11
 temperature and strain rate 247
 temperature effects 246
 temporary attachment 43
 temporary snap-fits 43
 thermal contraction 137
 thermal effects 147

thermal expansion 137, 156
 thickness-tapered beams 299
 thin walls 206
 threaded fastener joints 20
 threaded fasteners 134, 223
 threaded fastener technology
 – vs. snap-fit 35
 threshold angle 261
 tip 52, 212
 toggle switch application 154, 165
 torsional locks 80, 107, 265
 total installed cost 30, 32
 toughness 247
 track locators 58
 translational constraint 147
 translational DOM 147
 trap(s) 263, 325
 – and column mechanics 99
 – as buckles 103
 – assembly 101
 – lock behavior 99
 – locks 80, 98, 297
 – prong lock pair 92
 – separation 101
 tunable locators 68
 twelve degrees-of motion 133
 twist 52
 two-part locks 109

U

ultimate strength 237
 ultra-violet effects 246
 under-constraint 82, 136–137, 156–157
 undercut 260
 U-nuts 224
 user-feel 176, 180, 198
 utilitarian attachment 43

V

visuals 176, 198
 void-based locators 56, 61
 voids 56, 190

W

wall deflection adjustment 279
 wedge locators 59
 width-tapered beams 304
 wing lock 109

Y

yield point 237
 yield strength 237